

MATLAB EXPO

2021

Radar Systems Engineering: Making the Right Design Choices for Next Generation Designs

Rick Gentile



Mike Rudolph



3 Things We'll Cover Today

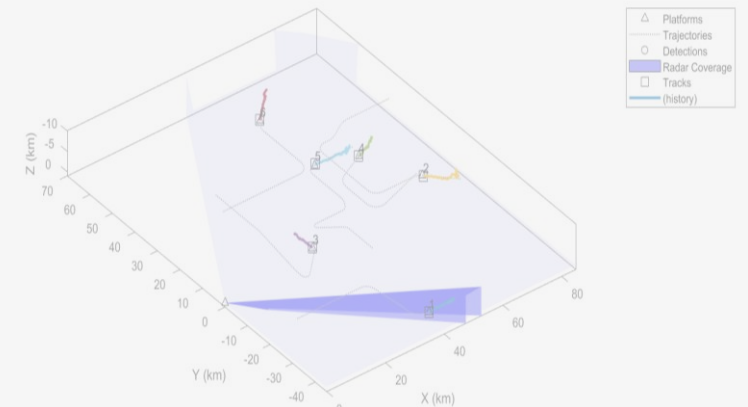
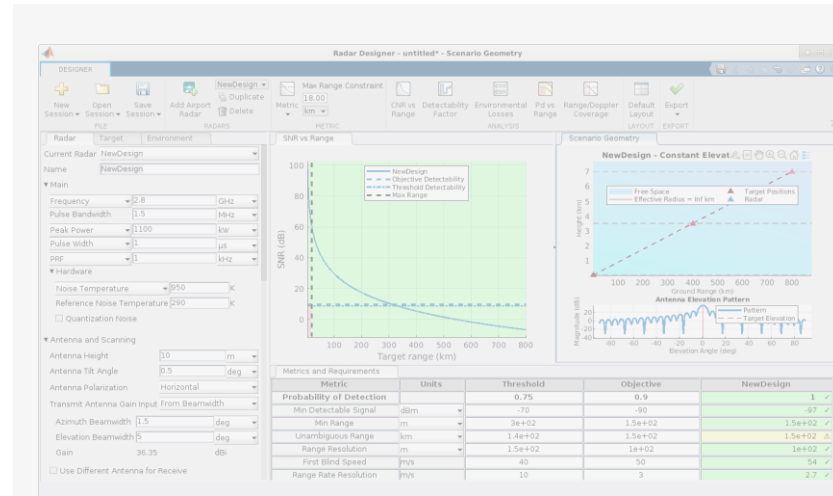
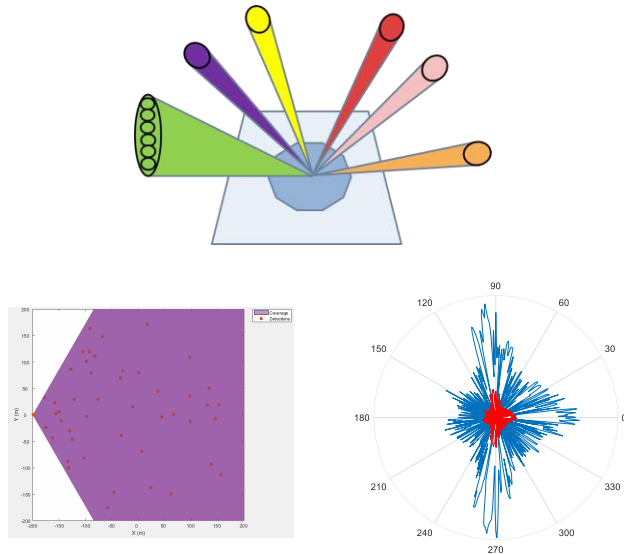

Challenges

Multifunction operations in harsh environmental conditions for smaller targets

Radar System Engineering

Making engineering trade-offs early in the design cycle

Modeling and Simulation

Selecting the right level of model abstraction

Today's radar systems perform multiple functions

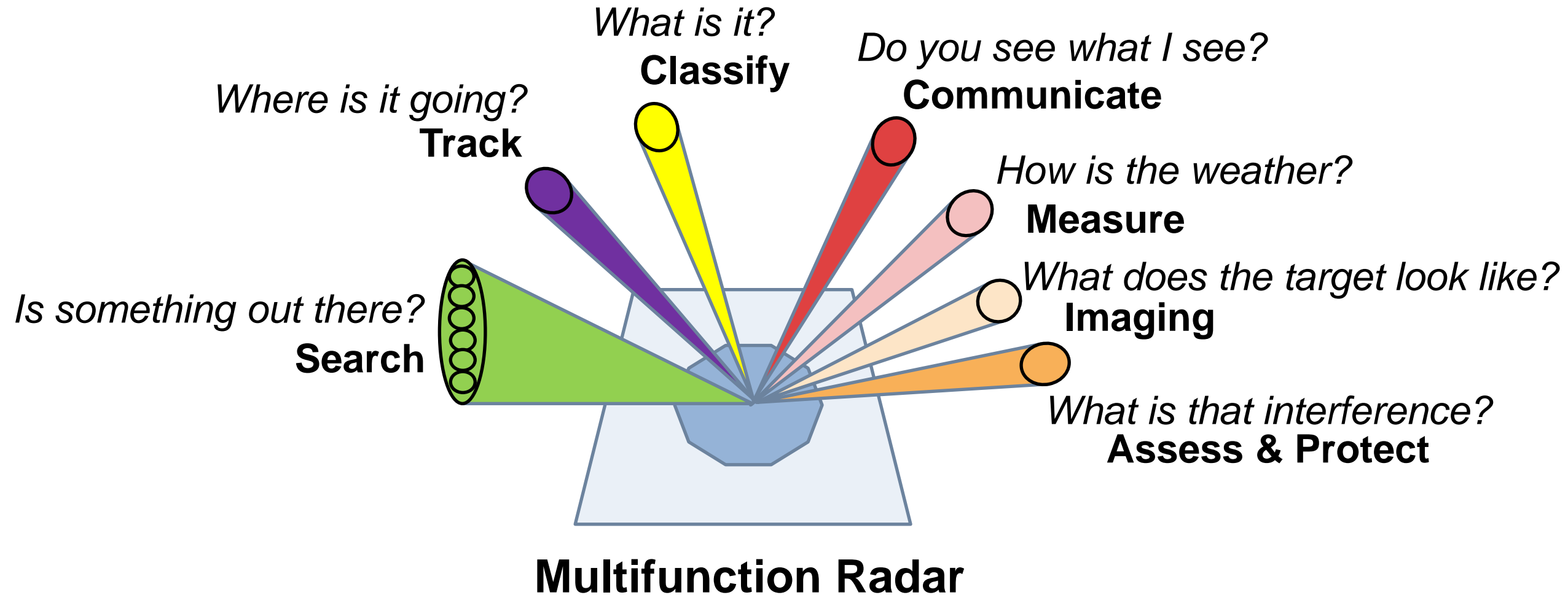

What are we missing? Where are you focused?

Radar systems need to detect smaller targets

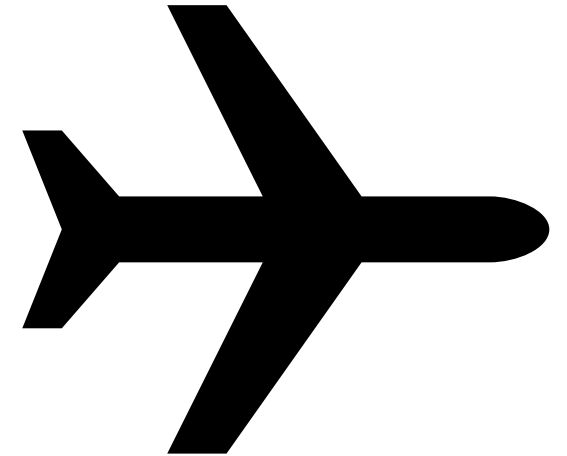
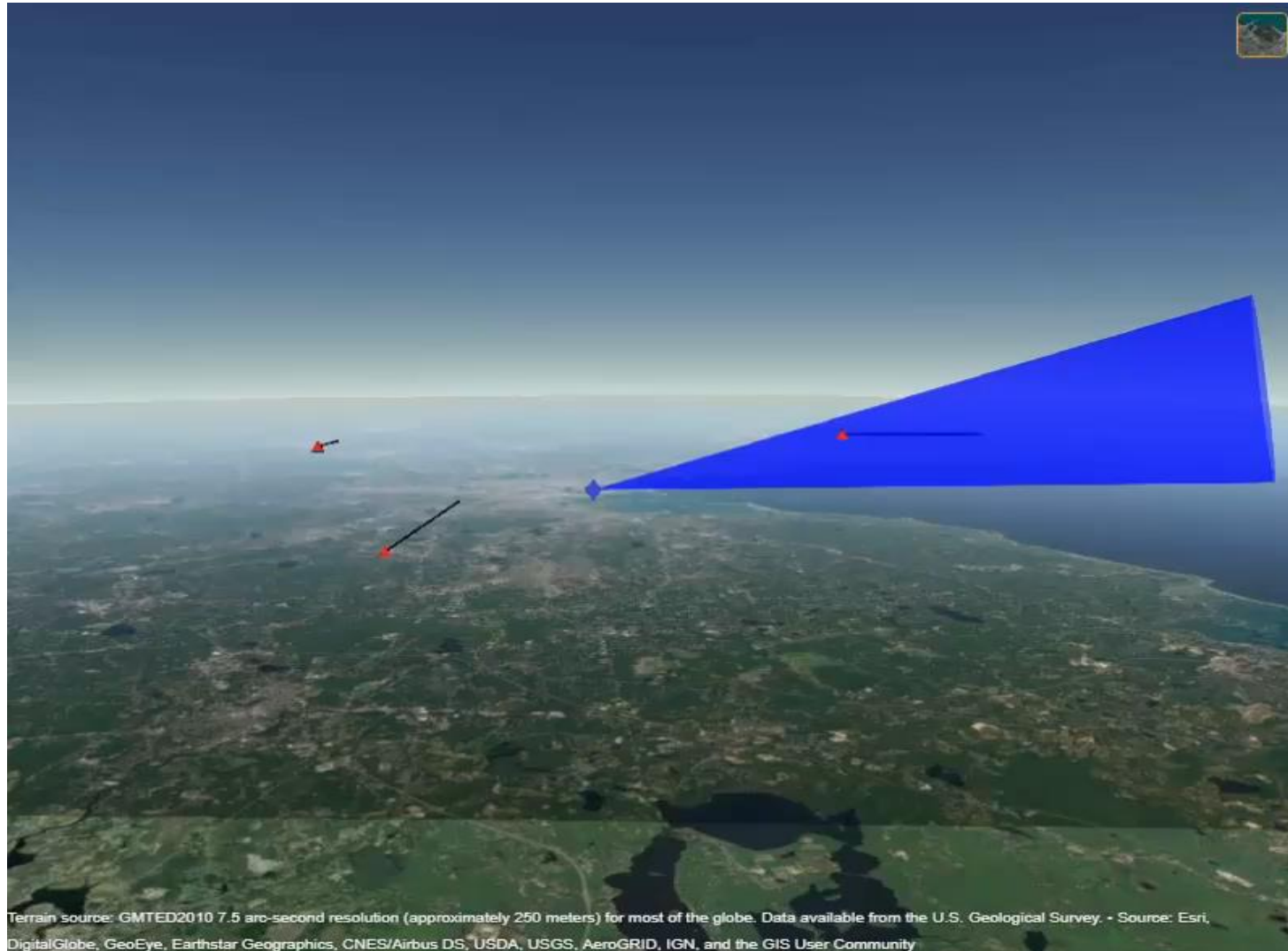

Smaller targets are harder to detect

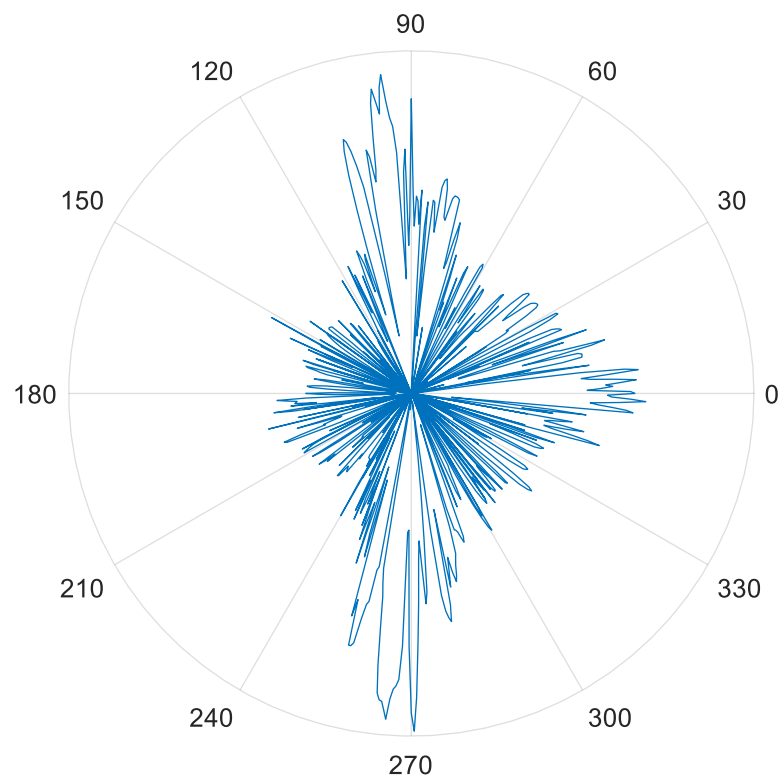

vs.

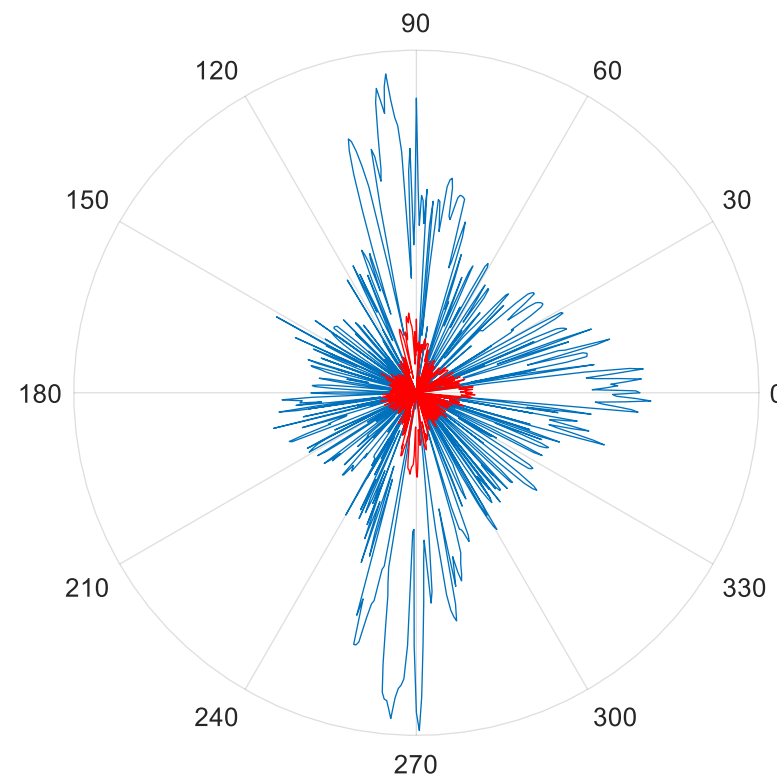

Radar cross section: dBsm vs. aspect angle

Typical RCS (m^2)
 Large aircraft 100
 Small UAV $\ll 1$

Smaller targets fly at lower altitudes where environmental conditions are a factor

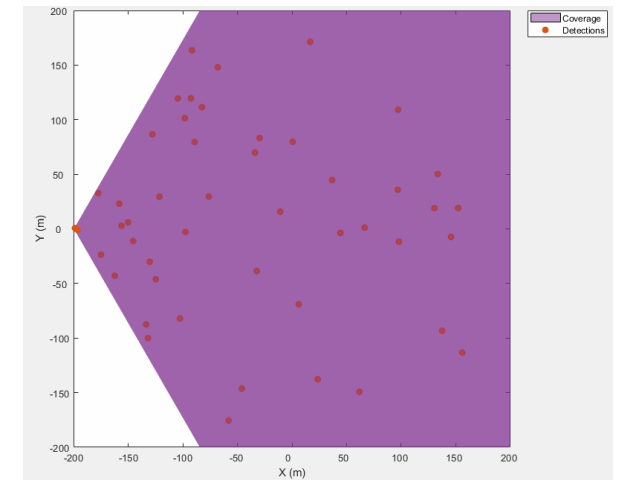
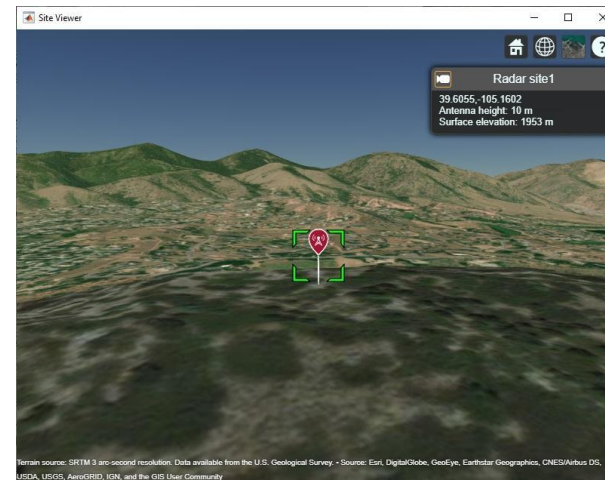
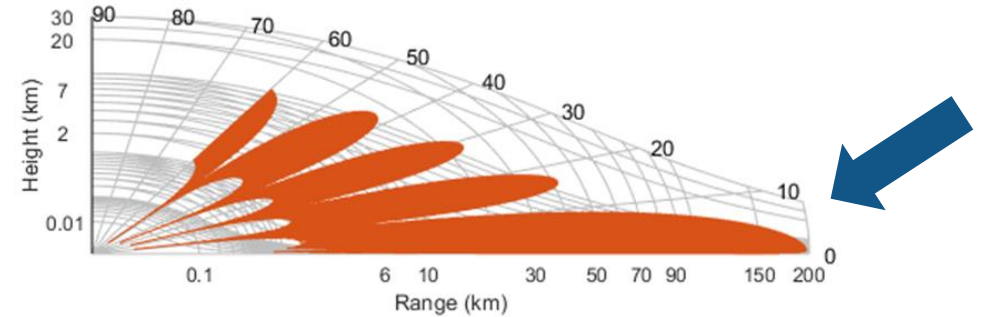
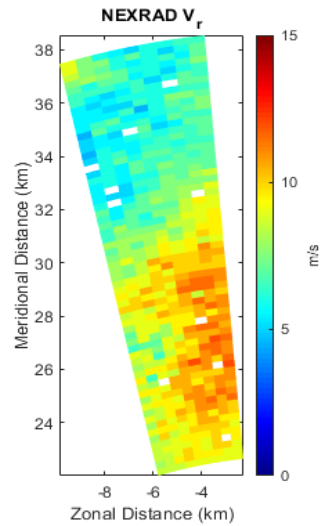
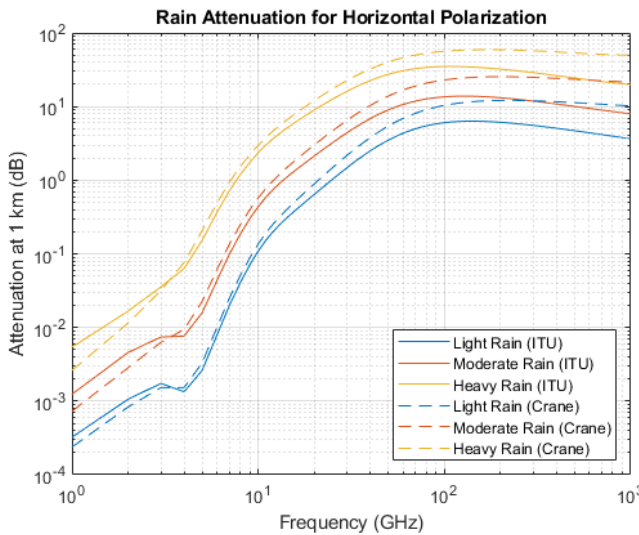

Propagation losses & clutter

Clutter returns from the terrain

A trade must be made between detections and false alarms

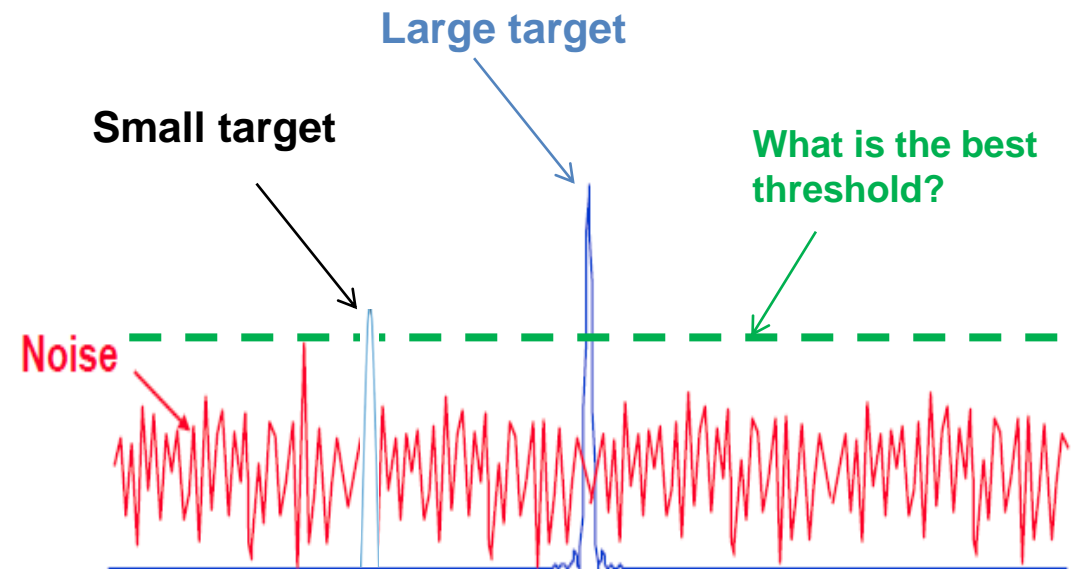
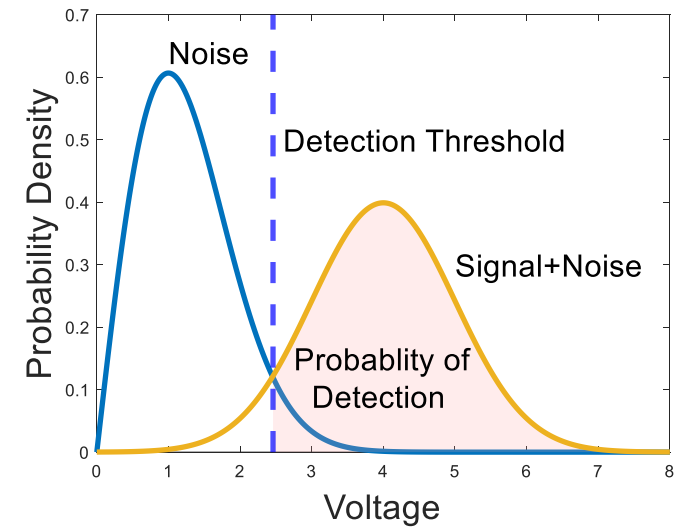
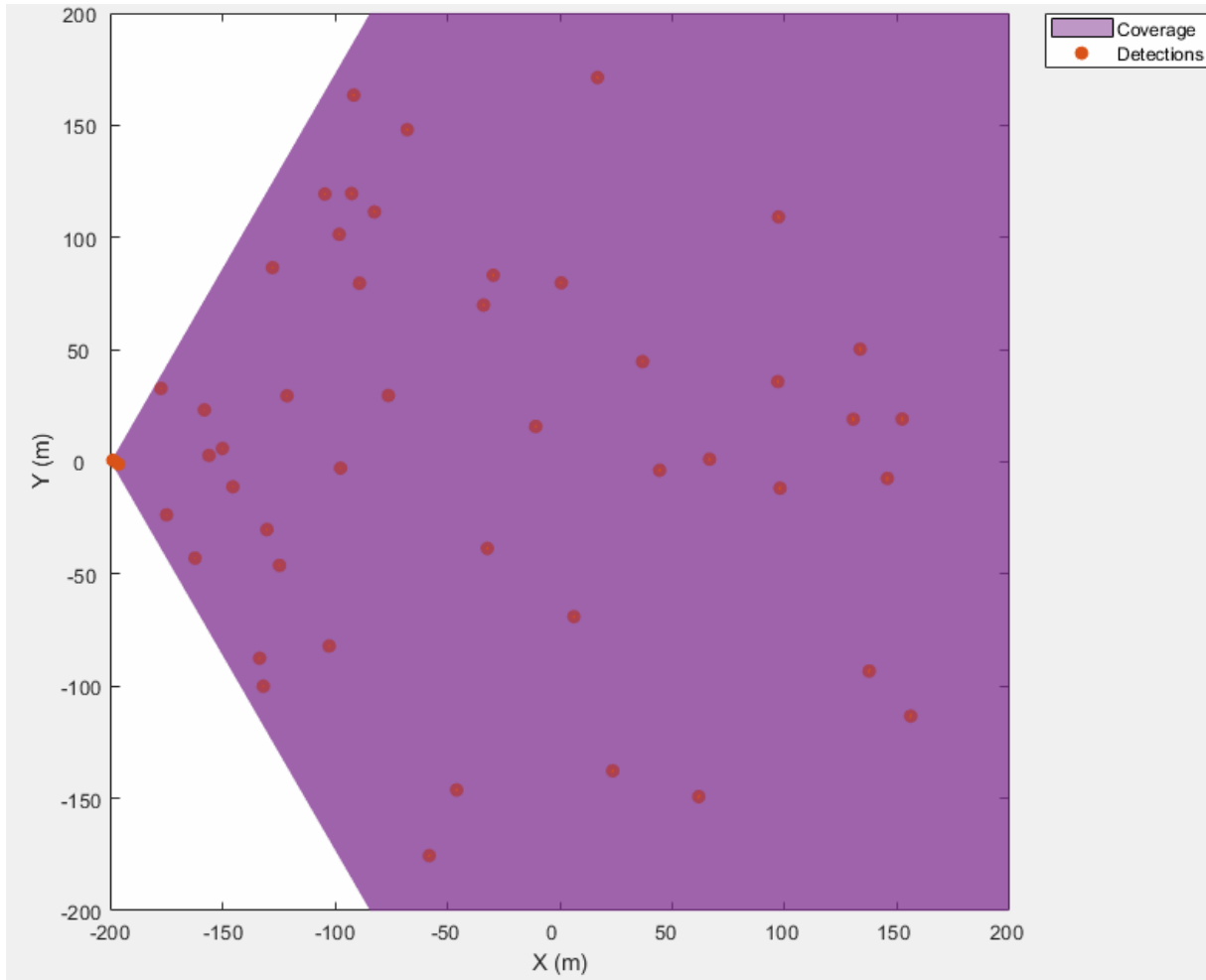

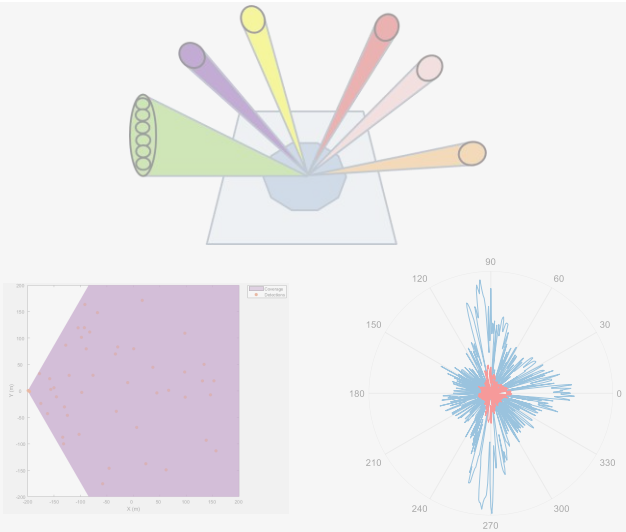

Challenges

Multifunction operations in harsh environmental conditions for smaller targets

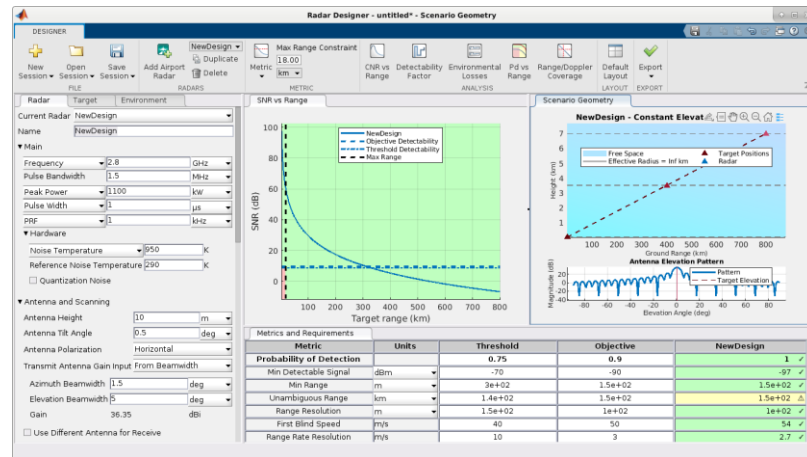

Radar System Engineering

Making engineering trade-offs early in the design cycle

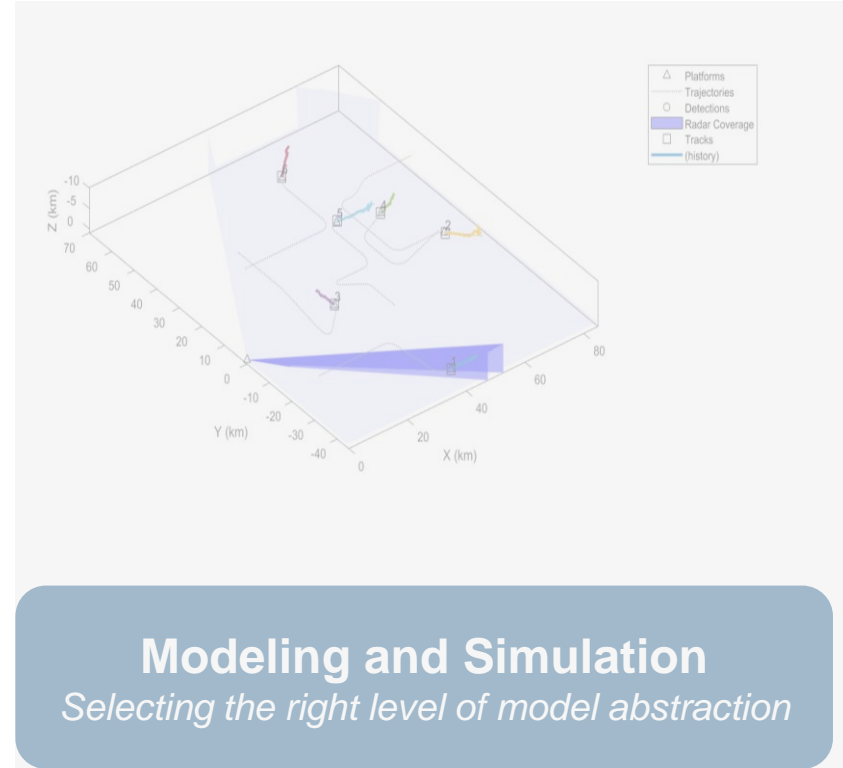



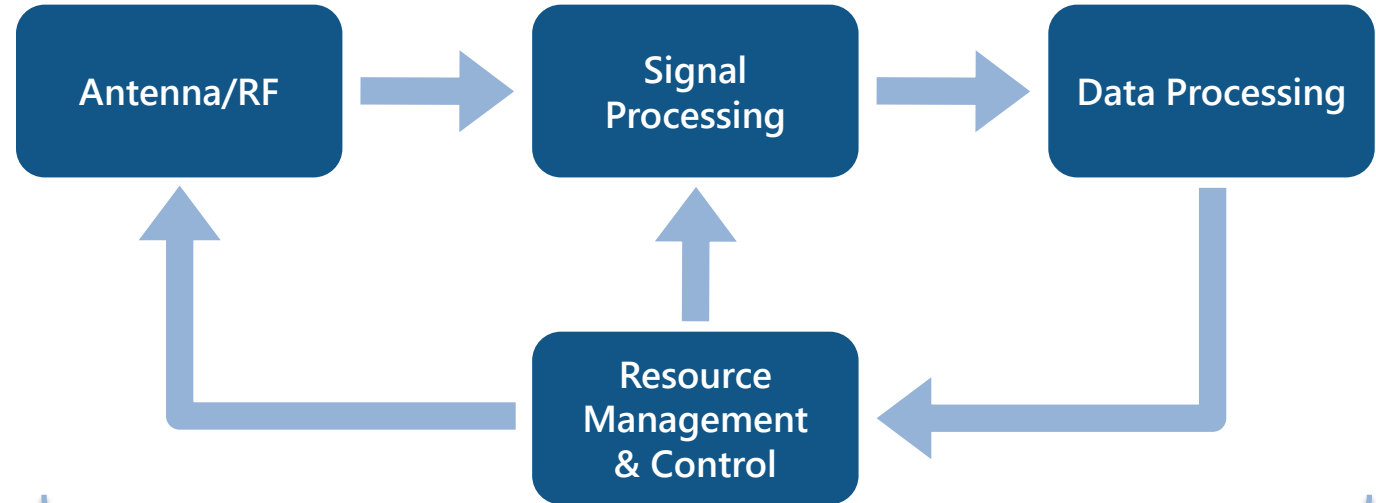

Modeling and Simulation

Selecting the right level of model abstraction

The design must work in for a range of environments and scenarios



-  **Target attributes**
-  **Surface clutter**
-  **Atmospheric conditions**
-  **Precipitation**

-  **Operating parameters**
-  **Hardware**
-  **Processing**
-  **Scanning**

Radar Designer App can help you interactively evaluate tradeoffs

Quick start with 5 built-in configurations

Export MATLAB script or formatted report

The screenshot displays the Radar Designer app interface with the following components:

- DESIGNER Toolbar:** Includes buttons for New Session, Open Session, Save Session, Add Airport Radar, Duplicate, Delete, Metric (310.00 km), Max Range Constraint, CNR vs Range, Detectability Factor, Environmental Losses, Pd vs Range, Range/Doppler Coverage, Default Layout, and Export.
- Configuration Panels:**
 - Radar:** Current Radar: AirportRadar, Name: AirportRadar.
 - Main:** Frequency: 2.8 GHz, Pulse Bandwidth: 1.5 MHz, Peak Power: 1100 kW, Pulse Width: 1 μs, PRF: 1 kHz.
 - Hardware:** Noise Temperature: 950 K, Reference Noise Temperature: 290 K, Quantization Noise: .
 - Antenna and Scanning:** Antenna Height: 10 m, Antenna Tilt Angle: 0.5 deg, Antenna Polarization: Horizontal, Transmit Antenna Gain Input: From Beamwidth, Azimuth Beamwidth: 1.5 deg, Elevation Beamwidth: 5 deg, Gain: 36.35 dBi, Use Different Antenna for Receive: .
- SNR vs Range Plot:** Shows SNR (dB) vs Target range (km). A solid blue line represents the AirportRadar performance, a dashed blue line represents Objective Detectability, a dotted blue line represents Threshold Detectability, and a vertical dashed black line represents Max Range at 310 km.
- Scenario Geometry Plot:** Shows Height (km) vs Ground Range (km) for 'AirportRadar - Constant Elevation Angle Target'. It includes an 'Antenna Elevation Pattern' sub-plot showing Magnitude (dB) vs Elevation Angle (deg).
- Metrics and Requirements Table:**

Metric	Units	Threshold	Objective	AirportRadar
Probability of Detection		0.75	0.9	0.93 ✓
Min Detectable Signal	dBm	-70	-90	-97 ✓
Min Range	m	3e+02	1.5e+02	1.5e+02 ✓
Unambiguous Range	km	1.4e+02	1.5e+02	1.5e+02 ⚠
Range Resolution	m	1.5e+02	1e+02	1e+02 ✓
First Blind Speed	m/s	40	50	54 ✓
Range Rate Resolution	m/s	10	3	2.7 ✓

Poll question

What tools do you currently use for your preliminary radar system design?

DESIGNER



(No Radar Available)

FILE RADARS

METRIC ANALYSIS LAYOUT EXPORT

Radar Target Environment

Current Radar: (No Radar Available)

Name:

▼ Main

Frequency: GHz
 Pulse Bandwidth: MHz
 Peak Power: kW
 Duty Cycle:
 PRI: s

▼ Hardware

Noise Temperature: K
 Reference Noise Temperature: K
 Quantization Noise

▼ Antenna and Scanning

Antenna Height: m
 Antenna Tilt Angle: deg
 Antenna Polarization: Horizontal
 Transmit Antenna Gain Input: Manual
 Gain: dBi
 Use Different Antenna for Receive
 Scan Mode: None

▼ Detection and Tracking

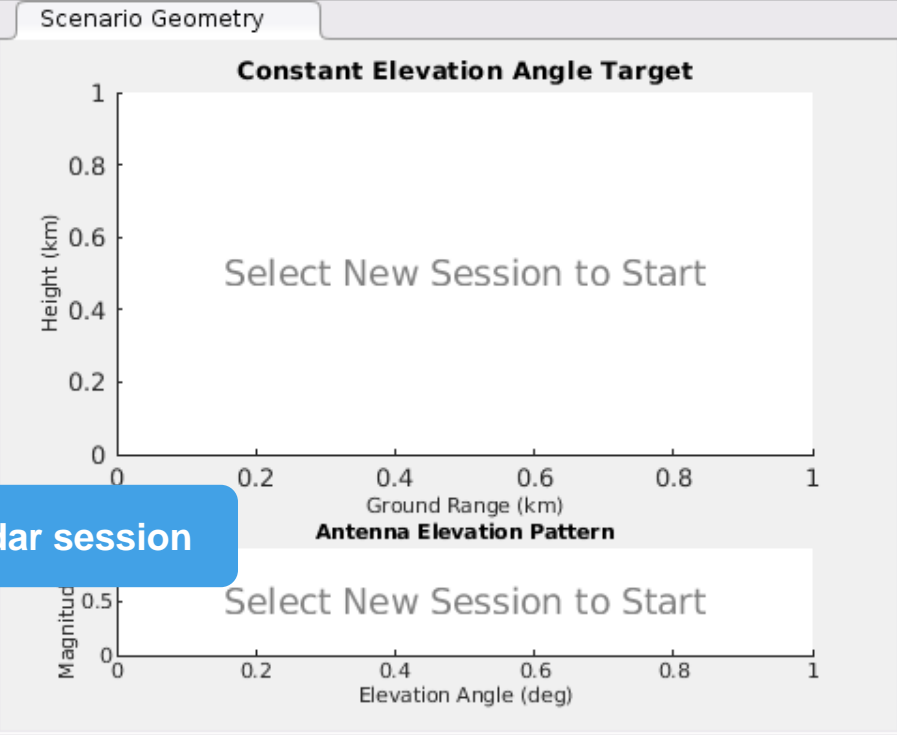
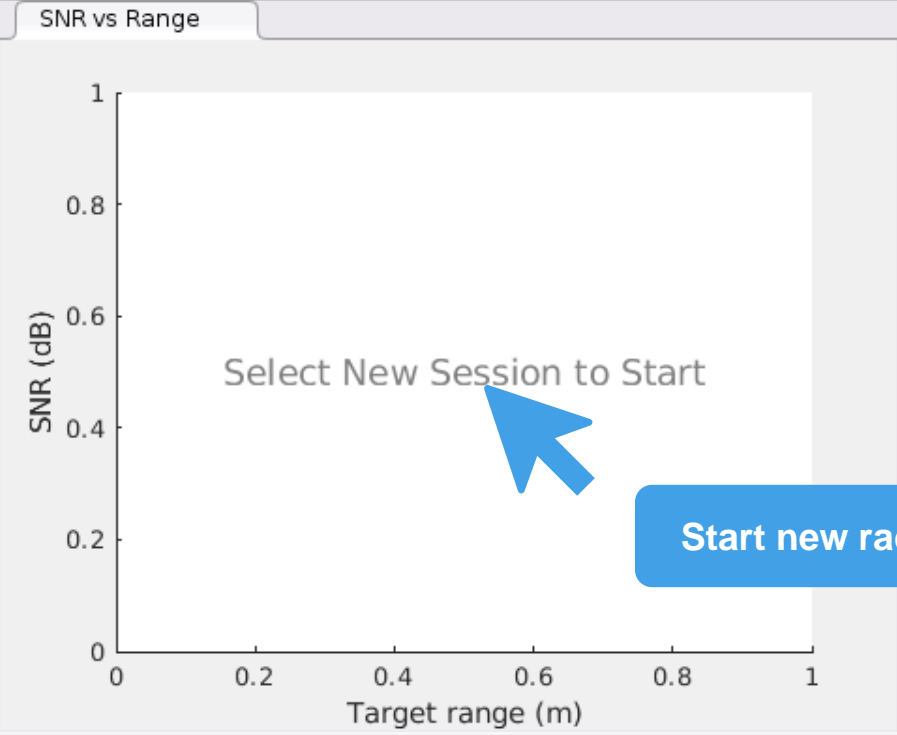

Start new radar session

Metrics and Requirements			
Metric	Units	Threshold	Objective
Probability of Detection			
Min Detectable Signal	dBm	--	--
Min Range	m	--	--
Unambiguous Range	km	--	--
Range Resolution	m	--	--
First Blind Speed	m/s	--	--
Range Rate Resolution	m/s	--	--

DESIGNER



FILE

(No Radar Available)

RADARS

Max Range Constraint

Metric:

METRIC

ANALYSIS LAYOUT EXPORT

Radar Target Environment

Current Radar: (No Radar Available)

Name:

▼ Main

Frequency: GHz

Pulse Bandwidth: MHz

Peak Power: kW

Duty Cycle:

PRI: s

▼ Hardware

Noise Temperature: K

Reference Noise Temperature: K

Quantization Noise

▼ Antenna and Scanning

Antenna Height: m

Antenna Tilt Angle: deg

Antenna Polarization:

Transmit Antenna Gain Input:

Gain: dBi

Use Different Antenna for Receive

Scan Mode:

▼ Detection and Tracking

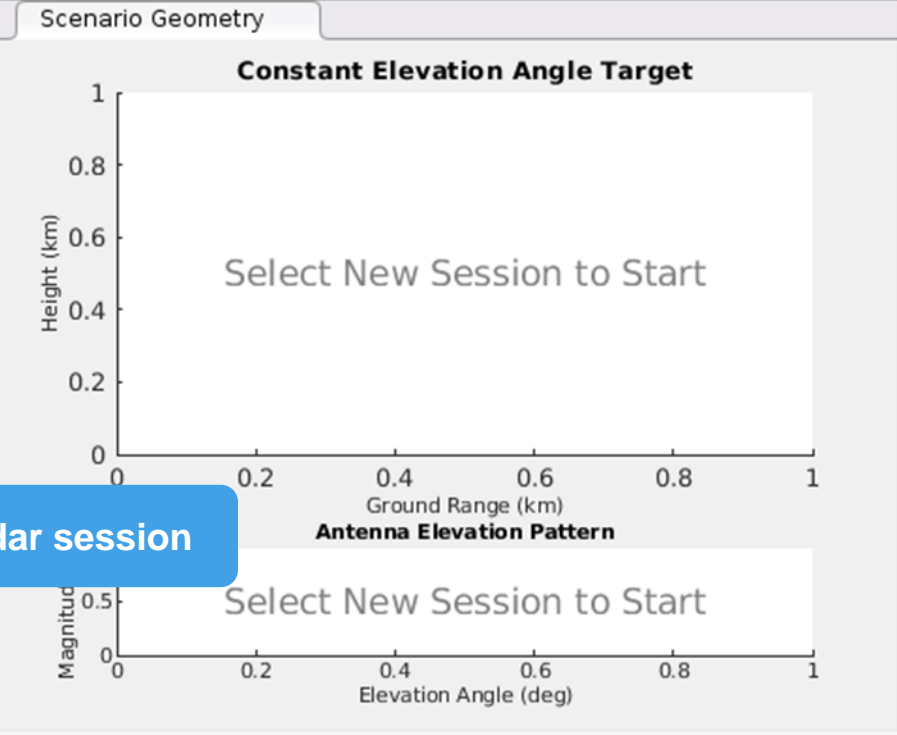
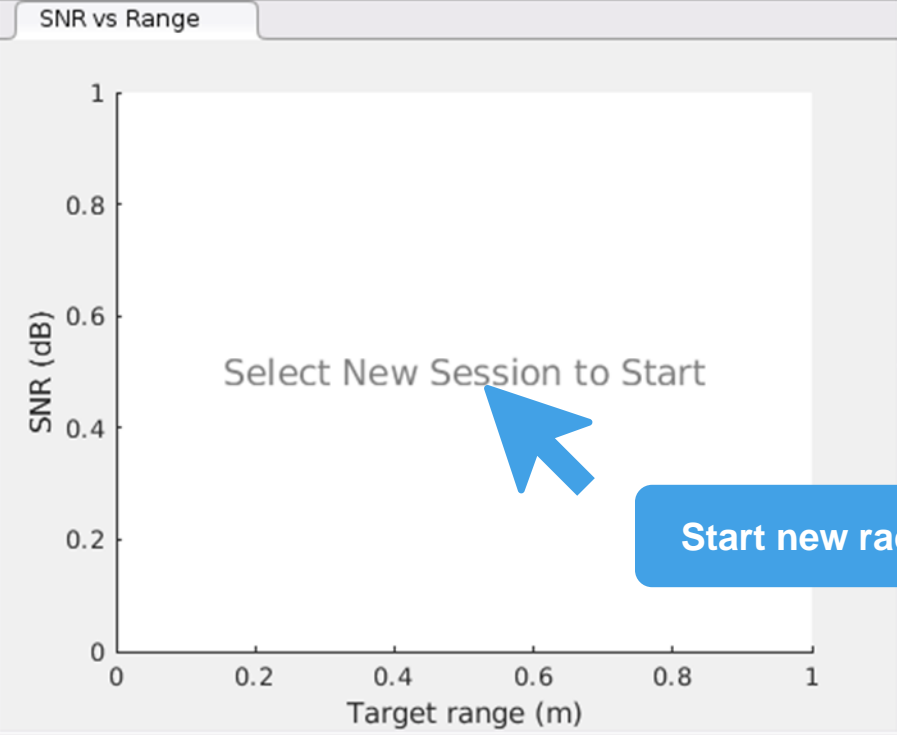

Start new radar session

Metrics and Requirements

Metric	Units	Threshold	Objective
Probability of Detection		--	--
Min Detectable Signal	dBm	--	--
Min Range	m	--	--
Unambiguous Range	km	--	--
Range Resolution	m	--	--
First Blind Speed	m/s	--	--
Range Rate Resolution	m/s	--	--

DESIGNER



(No Radar Available)

- Airborne Radar**
 Long-range, airborne surveillance radar
- Airport Radar**
 Terminal airport surveillance radar
- Automotive Radar**
 Automotive radar for Adaptive Cruise Control (ACC)
- Tracking Radar**
 Ground-based, cued tracking radar system
- Weather Radar**
 Clear air weather radar

Select airport radar template

Reference Noise Temperature K

Quantization Noise

▼ Antenna and Scanning

Antenna Height m

Antenna Tilt Angle deg

Antenna Polarization

Transmit Antenna Gain Input

Gain dBi

Use Different Antenna for Receive

Scan Mode

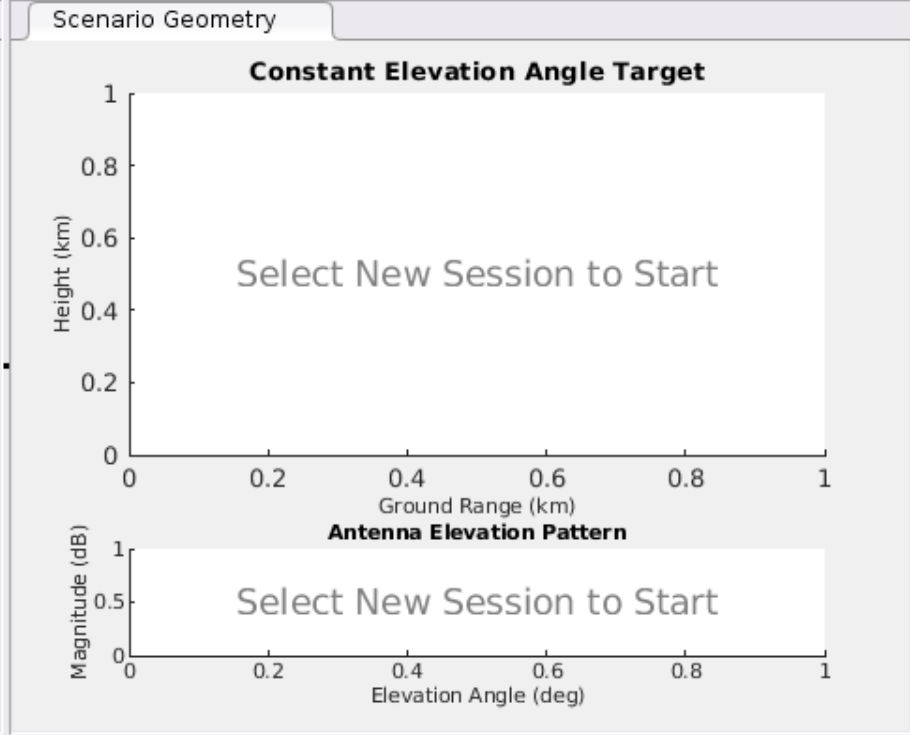
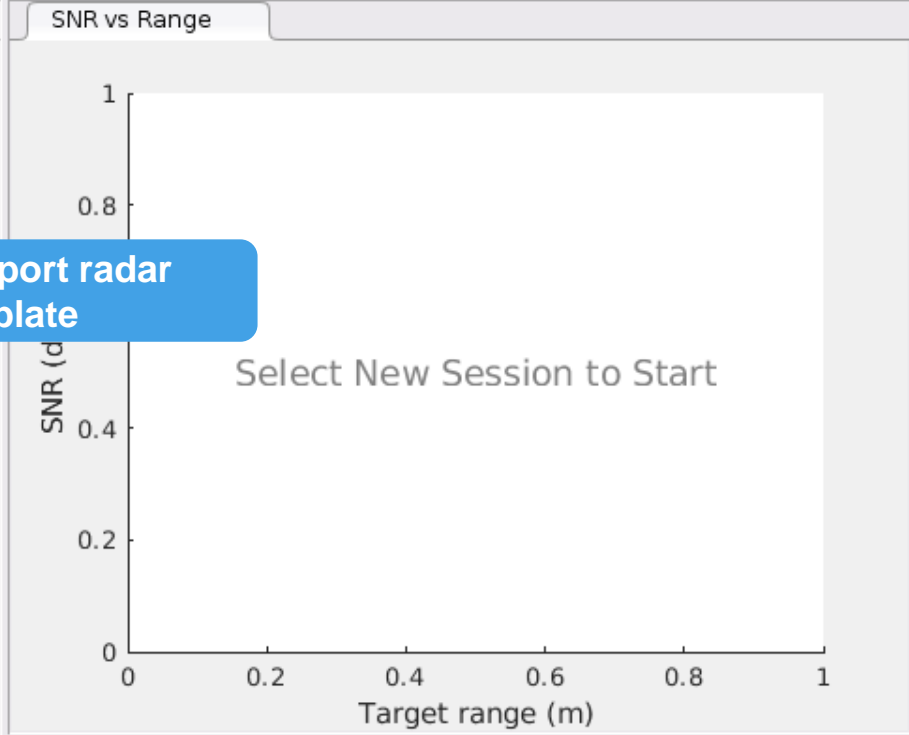

Metrics and Requirements			
Metric	Units	Threshold	Objective
Probability of Detection			
Min Detectable Signal	dBm	--	--
Min Range	m	--	--
Unambiguous Range	km	--	--
Range Resolution	m	--	--
First Blind Speed	m/s	--	--
Range Rate Resolution	m/s	--	--

DESIGNER



FILE RADARS

Metric: METRIC

ANALYSIS LAYOUT EXPORT

Current Radar:

Name:

▼ Main

Frequency: GHz
 Pulse Bandwidth: MHz
 Peak Power: kW
 Pulse Width: μs
 PRF: kHz

▼ Hardware

Noise Temperature: K
 Reference Noise Temperature: K
 Quantization Noise

▼ Antenna and Scanning

Antenna Height: m
 Antenna Tilt Angle: deg
 Antenna Polarization:
 Transmit Antenna Gain Input:
 Azimuth Beamwidth: deg
 Elevation Beamwidth: deg
 Gain: dBi
 Use Different Antenna for Receive

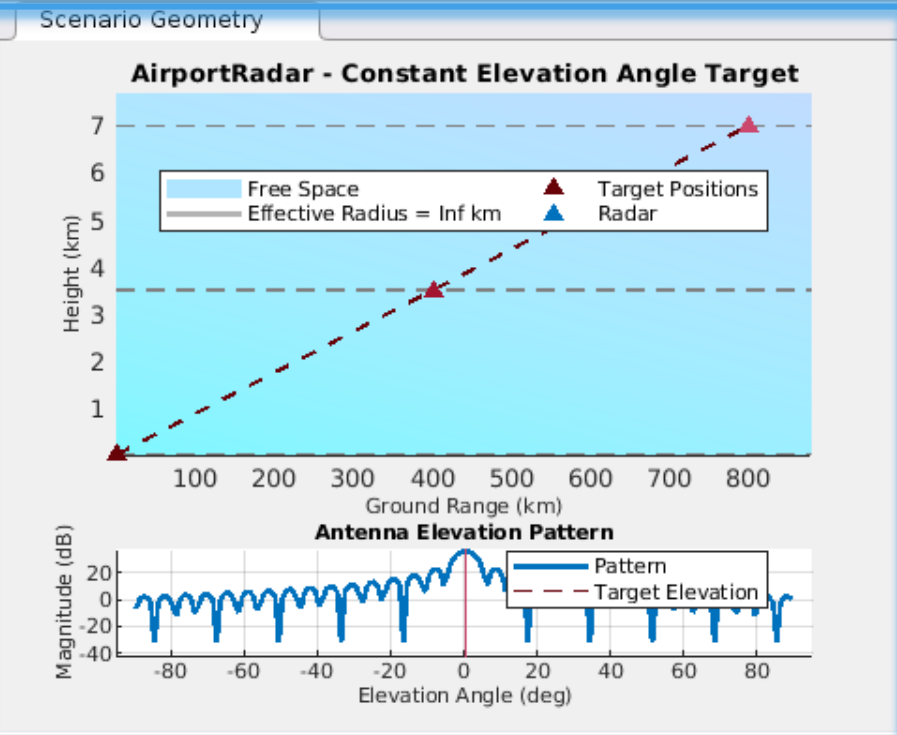
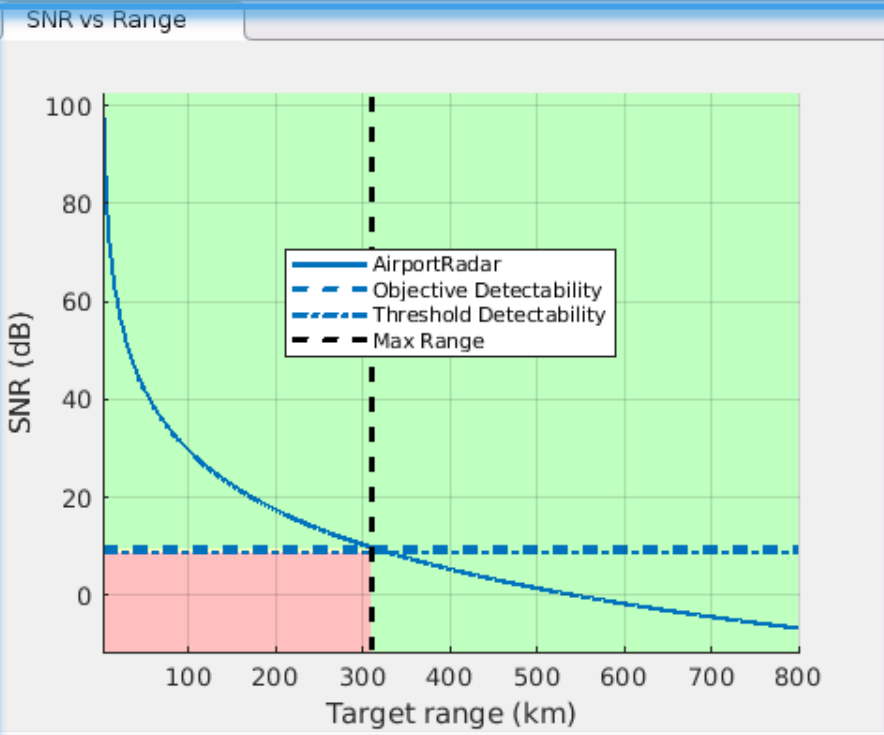

Metrics and Requirements				
Metric	Units	Threshold	Objective	AirportRadar
Probability of Detection		0.75	0.9	0.93 ✓
Min Detectable Signal	dBm	-70	-90	-97 ✓
Min Range	m	3e+02	1.5e+02	1.5e+02 ✓
Unambiguous Range	km	1.4e+02	1.5e+02	1.5e+02 ⚠
Range Resolution	m	1.5e+02	1e+02	1e+02 ✓
First Blind Speed	m/s	40	50	54 ✓
Range Rate Resolution	m/s	10	3	2.7 ✓

DESIGNER



FILE RADARS

Metric: 18.00
km

METRIC

ANALYSIS LAYOUT EXPORT

Radar: Target Environment
 Current Radar: NewDesign
 Name: NewDesign

▼ Main

Frequency: 2.8 GHz
 Pulse Bandwidth: 1.5 MHz
 Peak Power: 1100 kW
 Pulse Width: 1 μs
 PRF: 1 kHz

▼ Hardware

Noise Temperature: 950 K
 Reference Noise Temperature: 290 K
 Quantization Noise

▼ Antenna and Scanning

Antenna Height: 10 m
 Antenna Tilt Angle: 0.5 deg
 Antenna Polarization: Horizontal
 Transmit Antenna Gain Input: From Beamwidth
 Azimuth Beamwidth: 1.5 deg
 Elevation Beamwidth: 5 deg
 Gain: 36.35 dBi
 Use Different Antenna for Receive

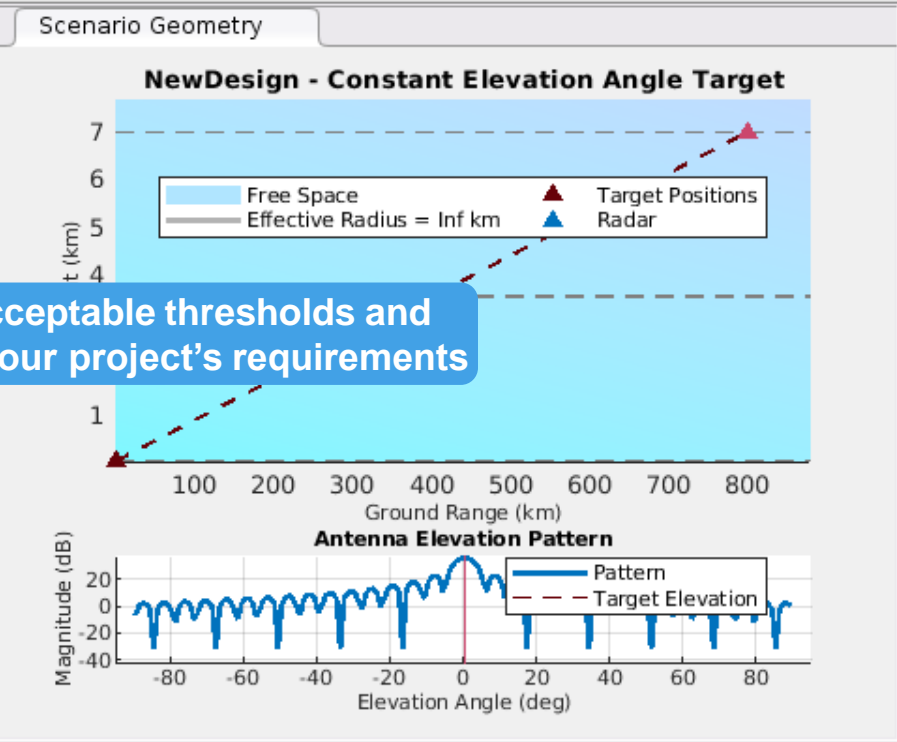
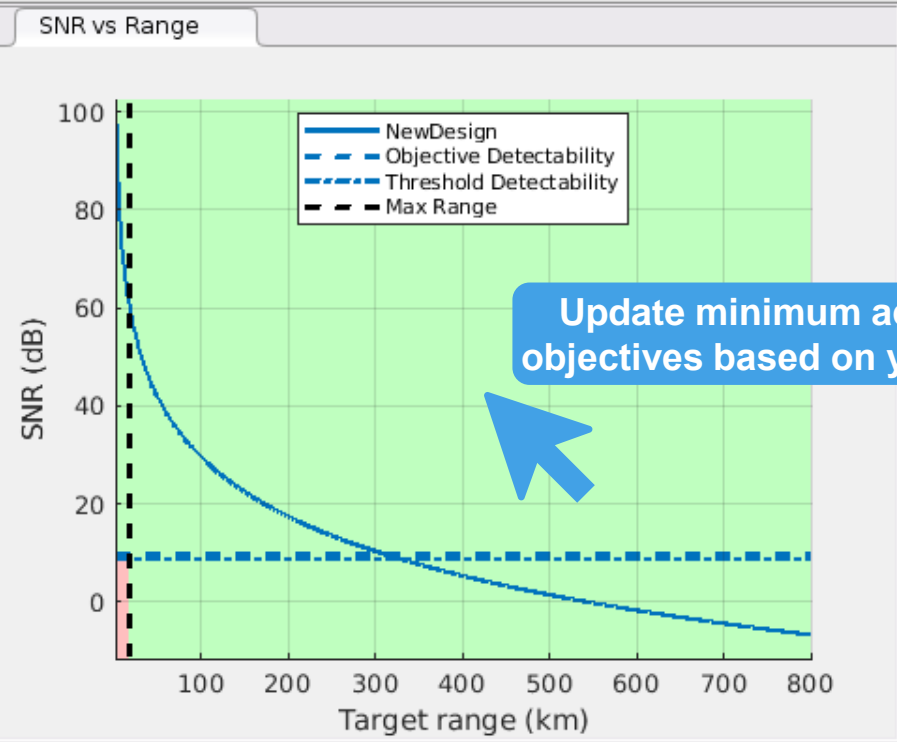

Metric	Units	Threshold	Objective	NewDesign
Probability of Detection		0.75	0.9	1 ✓
Min Detectable Signal	dBm	-70	-90	-97 ✓
Min Range	m	5e+02	3e+02	1.5e+02 ✓
Unambiguous Range	km	8	18	1.5e+02 ✓
Range Resolution	m	50	30	1e+02 X
First Blind Speed	m/s	80	1e+02	54 X
Range Rate Resolution	m/s	10	3	2.7 ✓

DESIGNER



FILE RADARS

Metric:

METRIC

ANALYSIS LAYOUT EXPORT

Radar Target Environment

Radar Cross Section:

Swerling Model:

Elevation Angle:

Max Acceleration:



Update target parameters

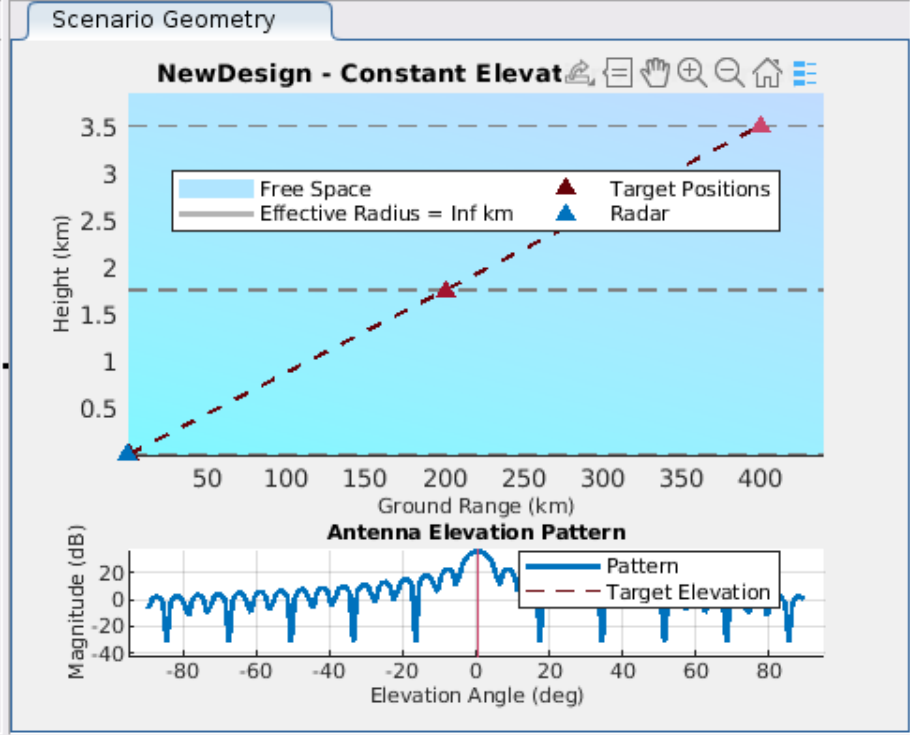
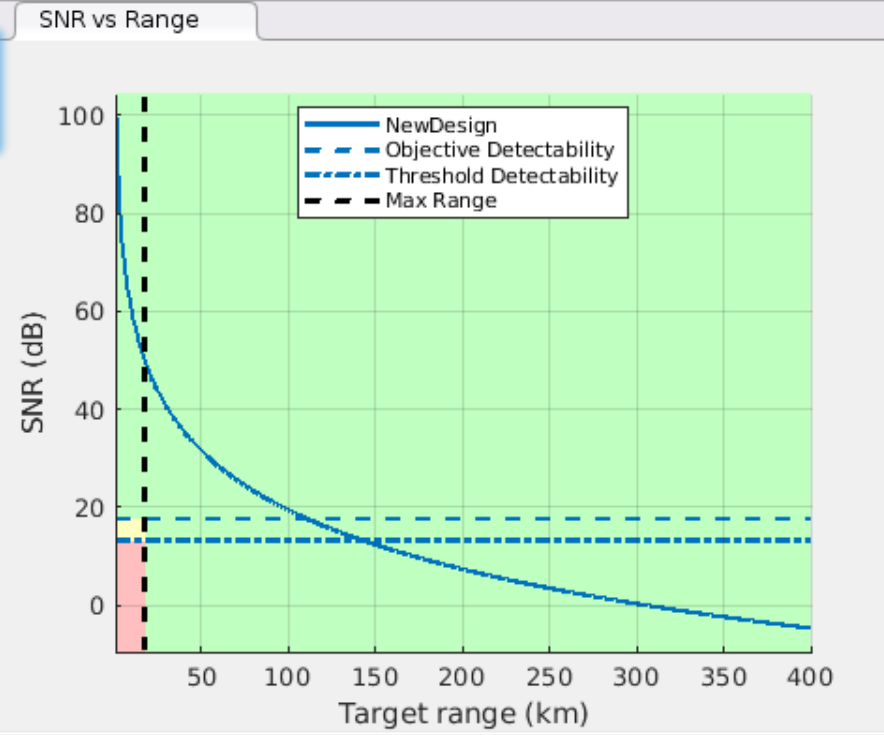

Metrics and Requirements

Metric	Units	Threshold	Objective	NewDesign
Probability of Detection		0.75	0.9	1 ✓
Min Detectable Signal	dBm	-70	-90	-89 ⚠
Min Range	m	5e+02	3e+02	1.5e+02 ✓
Unambiguous Range	km	8	18	1.5e+02 ✓
Range Resolution	m	50	30	1e+02 ✗
First Blind Speed	m/s	80	1e+02	54 ✗
Range Rate Resolution	m/s	10	3	2.7 ✓

Update radar design and note changes in the main body

Radar Target Environment
 Current Radar: NewDesign
 Name: NewDesign
 Main:
 Frequency: 9.5 GHz
 Pulse Bandwidth: 5 MHz
 Peak Power: 2 kW
 Pulse Width: 2 μs
 PRF: 7 kHz
 Hardware:
 Noise Temperature: 950 K
 Reference Noise Temperature: 290 K
 Antenna and Scanning:
 Antenna Height: 10 m
 Antenna Tilt Angle: 0.5 deg
 Antenna Polarization: Horizontal
 Transmit Antenna Gain Input: From Beamwidth
 Azimuth Beamwidth: 2 deg
 Elevation Beamwidth: 6 deg
 Gain: 34.31 dBi
 Use Different Antenna for Receive

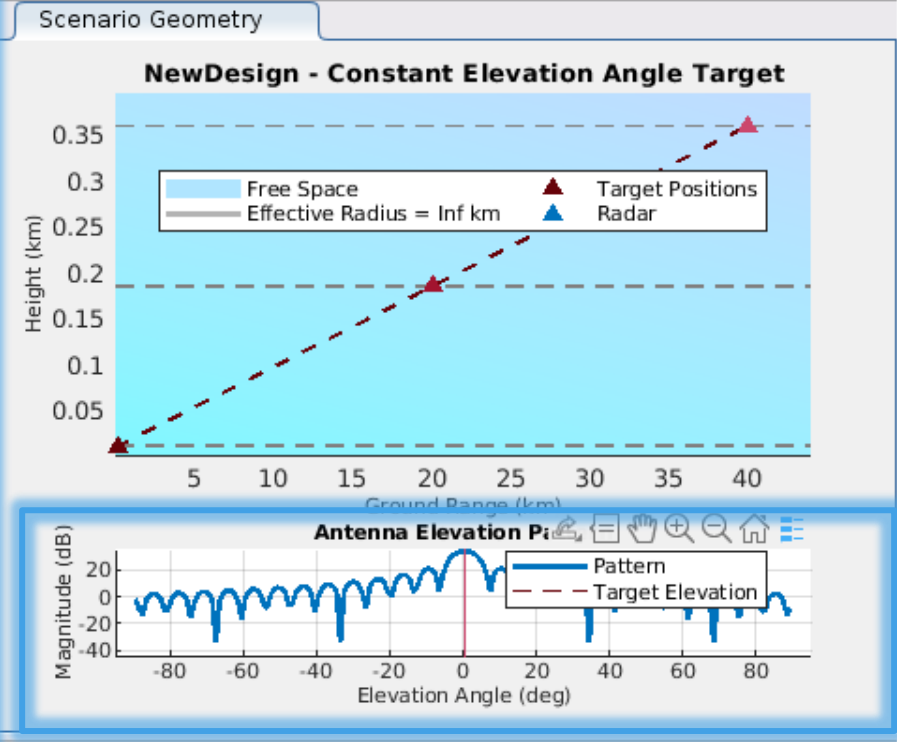
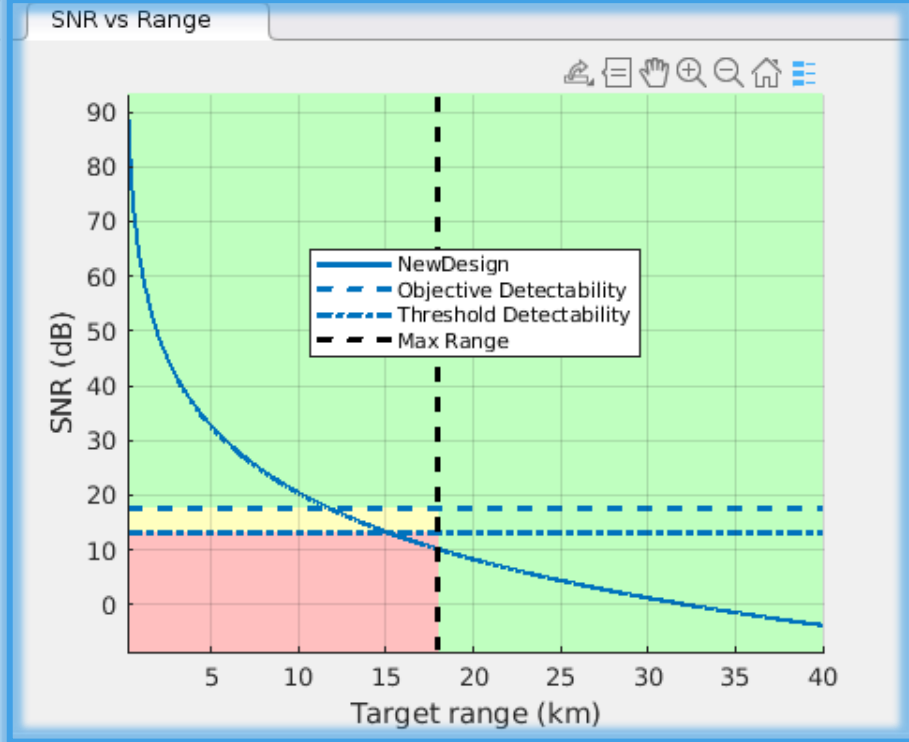

Metric	Units	Threshold	Objective	NewDesign
Probability of Detection		0.75	0.9	0.57 X
Min Detectable Signal	dBm	-70	-90	-84 Δ
Min Range	m	5e+02	3e+02	3e+02 ✓
Unambiguous Range	km	8	18	21 ✓
Range Resolution	m	50	30	30 ✓
First Blind Speed	m/s	80	1e+02	1.1e+02 ✓
Range Rate Resolution	m/s	10	3	5.5 Δ

DESIGNER



FILE RADARS

METRIC ANALYSIS LAYOUT EXPORT

Radar Target Environment
 Current Radar: NewDesign
 Name: NewDesign

▼ Main

Frequency: 9.5 GHz
 Pulse Bandwidth: 5 MHz
 Peak Power: 2 kW
 Pulse Width: 2 μs
 PRF: 7 kHz

▼ Hardware

Noise Temperature: 950 K
 Reference Noise Temperature: 290 K
 Quantization Noise

▼ Antenna and Scanning

Antenna Height: 10 m
 Antenna Tilt Angle: 0.5 deg
 Antenna Polarization: Horizontal
 Transmit Antenna Gain Input: From Beamwidth
 Azimuth Beamwidth: 2 deg
 Elevation Beamwidth: 6 deg
 Gain: 34.31 dBi
 Use Different Antenna for Receive

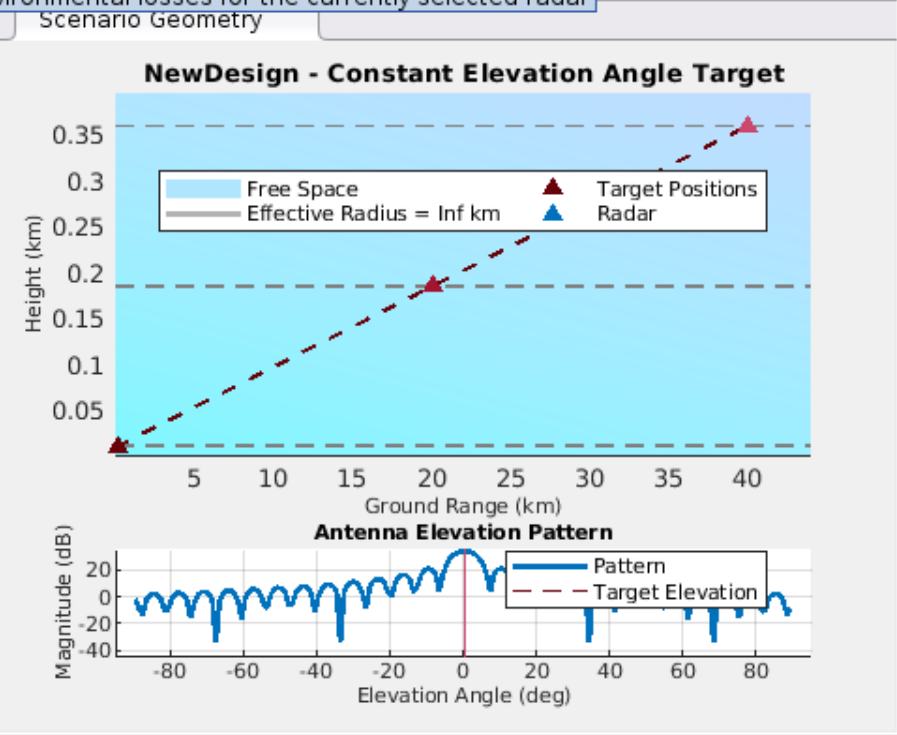
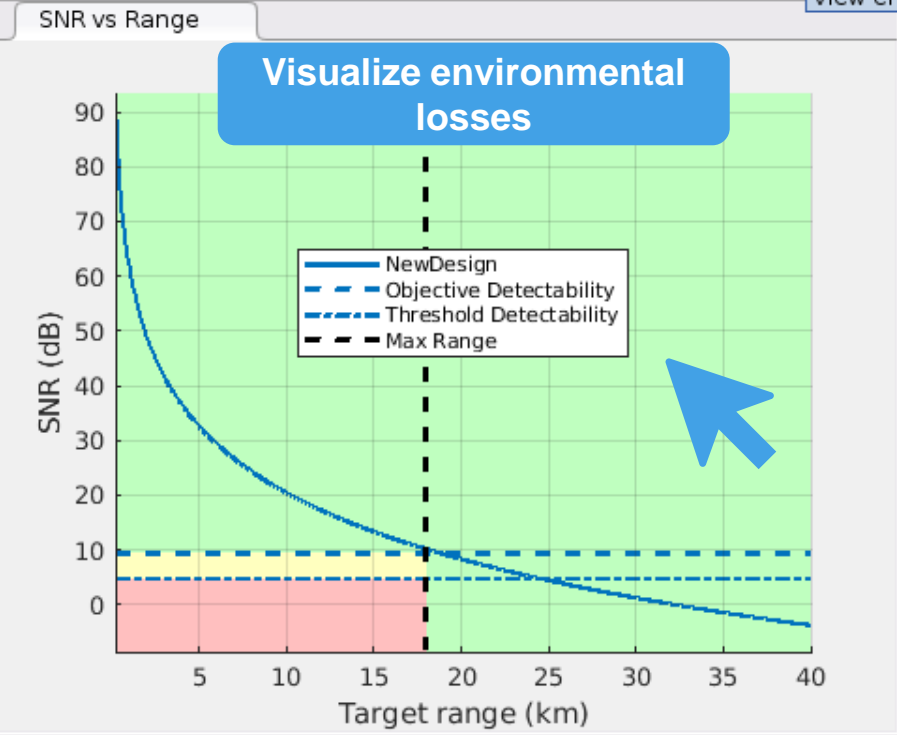

View environmental losses for the currently selected radar

Metrics and Requirements

Metric	Units	Threshold	Objective	NewDesign
Probability of Detection		0.75	0.9	0.92 ✓
Min Detectable Signal	dBm	-70	-90	-92 ✓
Min Range	m	5e+02	3e+02	3e+02 ✓
Unambiguous Range	km	8	18	21 ✓
Range Resolution	m	50	30	30 ✓
First Blind Speed	m/s	80	1e+02	1.1e+02 ✓
Range Rate Resolution	m/s	10	3	3.7 ⚠

DESIGNER



FILE

RADARS

Metric: 18.00 km

METRIC

ANALYSIS

LAYOUT EXPORT

Radars | Target | Environment

▼ Atmosphere and Surface

Free Space

▼ Precipitation

Precipitation Type: Rain

Model: ITU

Precipitation Start Range: 0 km

Precipitation Range Extent: 20 km

Rain Rate: 16 mm/hr

Statistical Percentage: 0.01 %

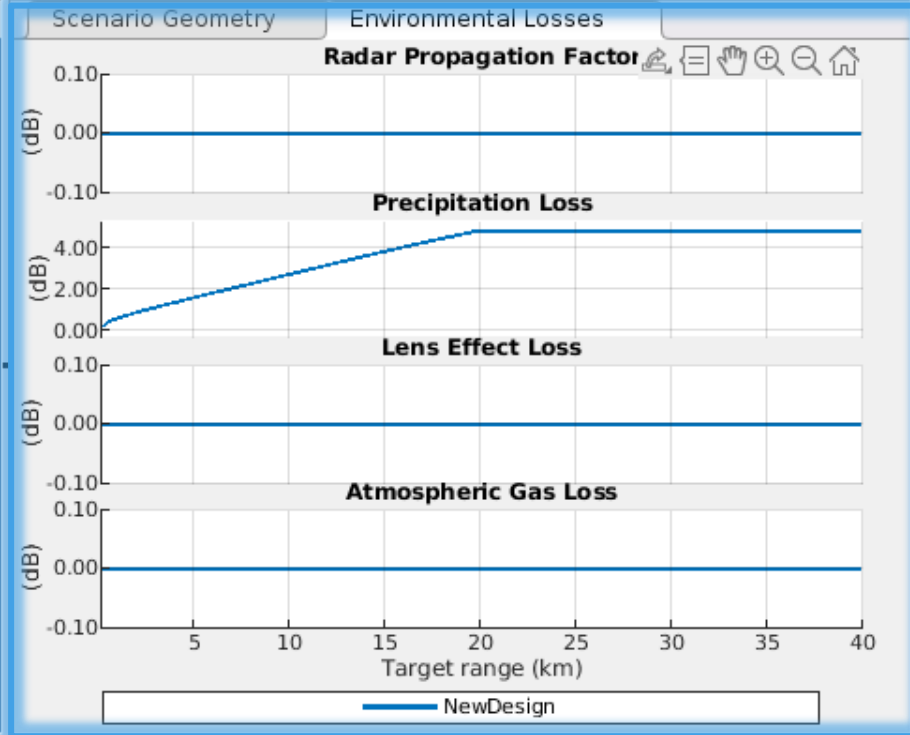
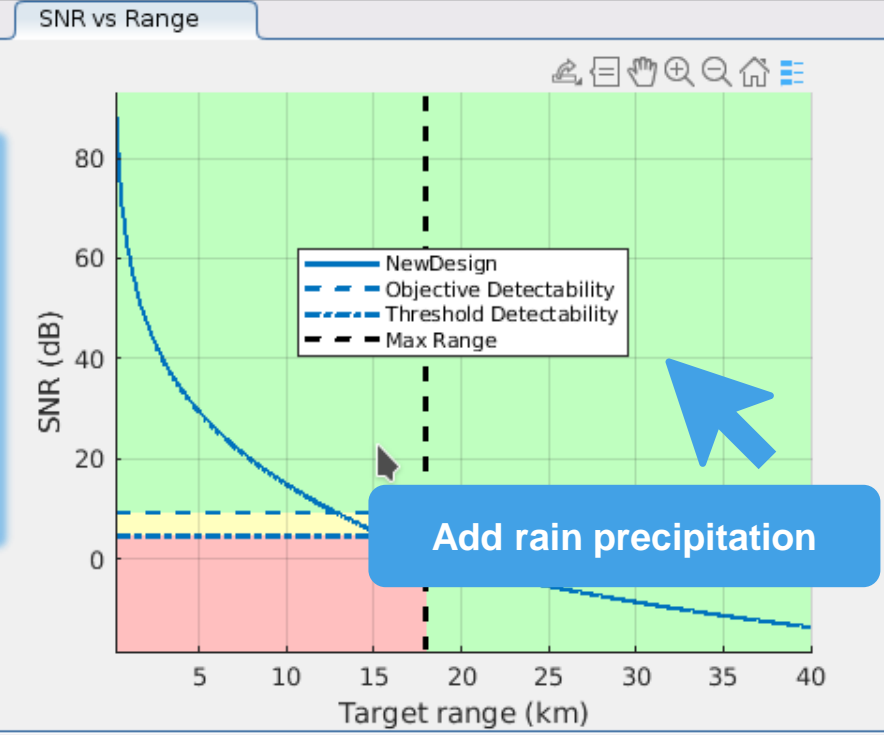

Metric	Units	Threshold	Objective	NewDesign
Probability of Detection		0.75	0.9	0.55 X
Min Detectable Signal	dBm	-70	-90	-92 ✓
Min Range	m	5e+02	3e+02	3e+02 ✓
Unambiguous Range	km	8	18	21 ✓
Range Resolution	m	50	30	30 ✓
First Blind Speed	m/s	80	1e+02	1.1e+02 ✓
Range Rate Resolution	m/s	10	3	3.7 ⚠

DESIGNER



FILE RADARS

Metric: 18.00 km

METRIC

Radar Target Environment
 Gain: 34.31 dBi
 Use Different Antenna for Receive
 Scan Mode: Mechanical
 Azimuth Scan Sector Size: 360 deg
 Elevation Scan Limits: 0 to 60 deg
 Max Scan Rate: 466.7 deg/s
 Search Volume Size: 5.441 sr
 Search Time: 6.38 s
 Probability of False Alarm: 1e-06
 Number of Pulses: 30
 Pulse Integration: Coherent
 Constant False Alarm Rate (CFAR)
 Number of CPIs: 3
 M-of-N CPI Integration
 Number of CPIs with Detection: 2
 Sensitivity Time Control (STC)
 Track Confirmation Logic
 Loss Factors: Eclipsing - Statistical Loss

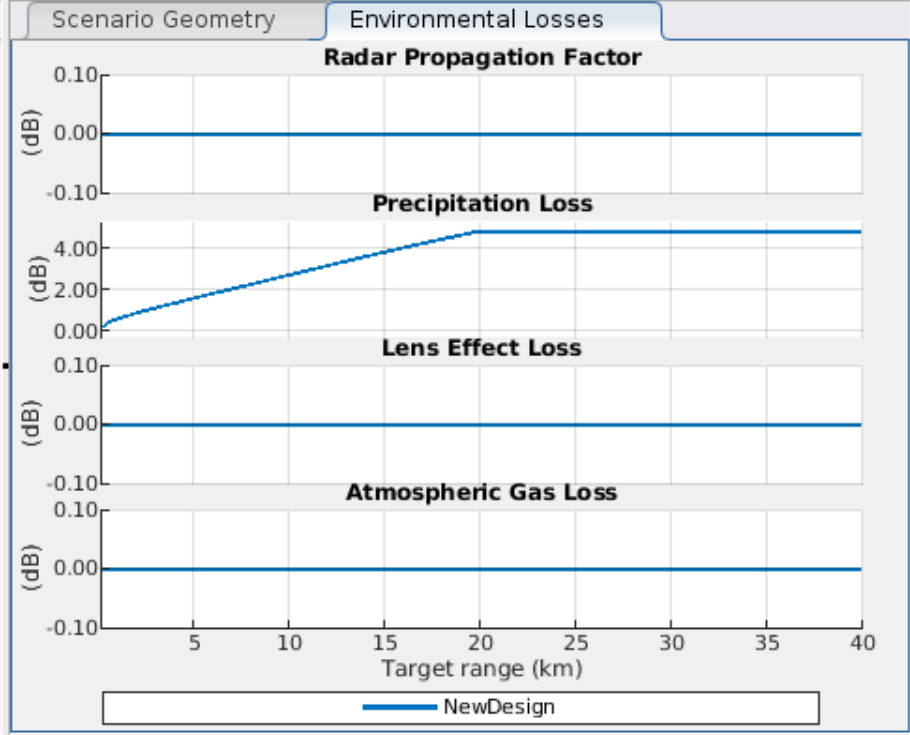
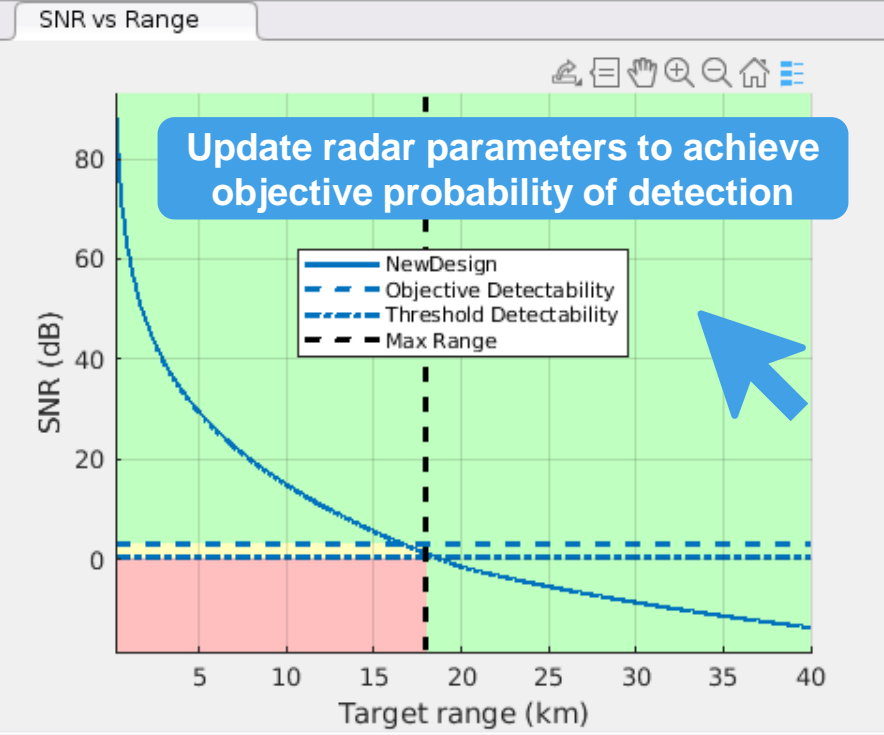

Metrics and Requirements

Metric	Units	Threshold	Objective	NewDesign
Probability of Detection		0.75	0.9	0.81 ⚠
Min Detectable Signal	dBm	-70	-90	-99 ✓
Min Range	m	5e+02	3e+02	3e+02 ✓
Unambiguous Range	km	8	18	21 ✓
Range Resolution	m	50	30	30 ✓
First Blind Speed	m/s	80	1e+02	1.1e+02 ✓
Range Rate Resolution	m/s	10	3	3.7 ⚠

DESIGNER



FILE RADARS

Metric:

METRIC

ANALYSIS LAYOUT

Radar:

 Target:

 Environment:

Current Radar:

 Name:

▼ Main

Frequency: GHz

 Pulse Bandwidth: MHz

 Peak Power: kW

 Pulse Width: μs

 PRF: kHz

▼ Hardware

Noise Temperature: K

 Reference Noise Temperature: K

 Quantization Noise

▼ Antenna and Scanning

Antenna Height: m

 Antenna Tilt Angle: deg

 Antenna Polarization:

 Transmit Antenna Gain Input:

 Azimuth Beamwidth: deg

 Elevation Beamwidth: deg

 Gain: dBi

 Use Different Antenna for Receive

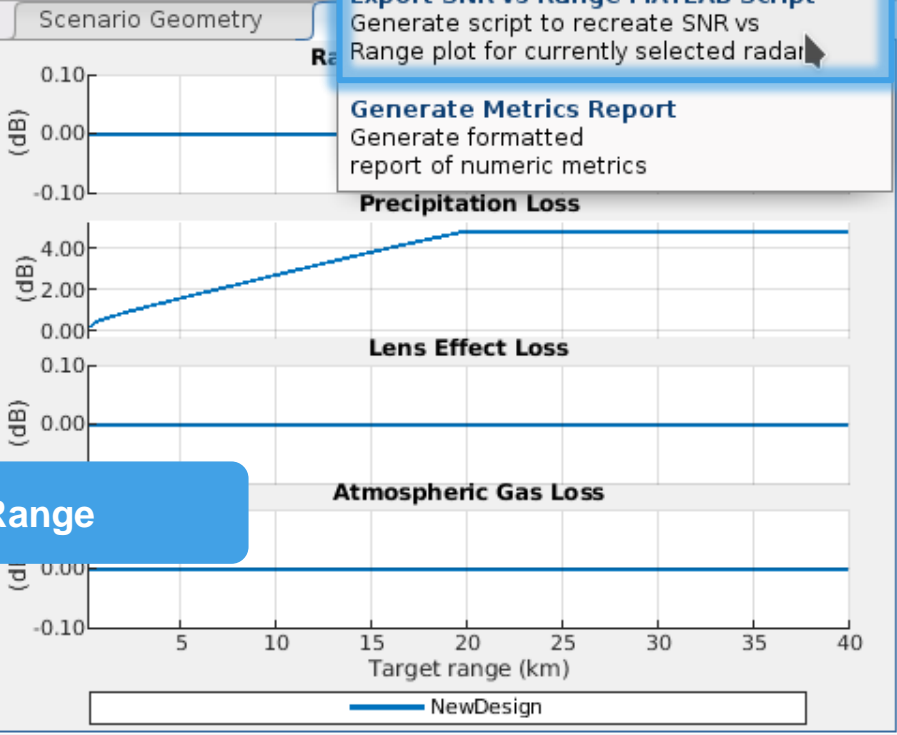
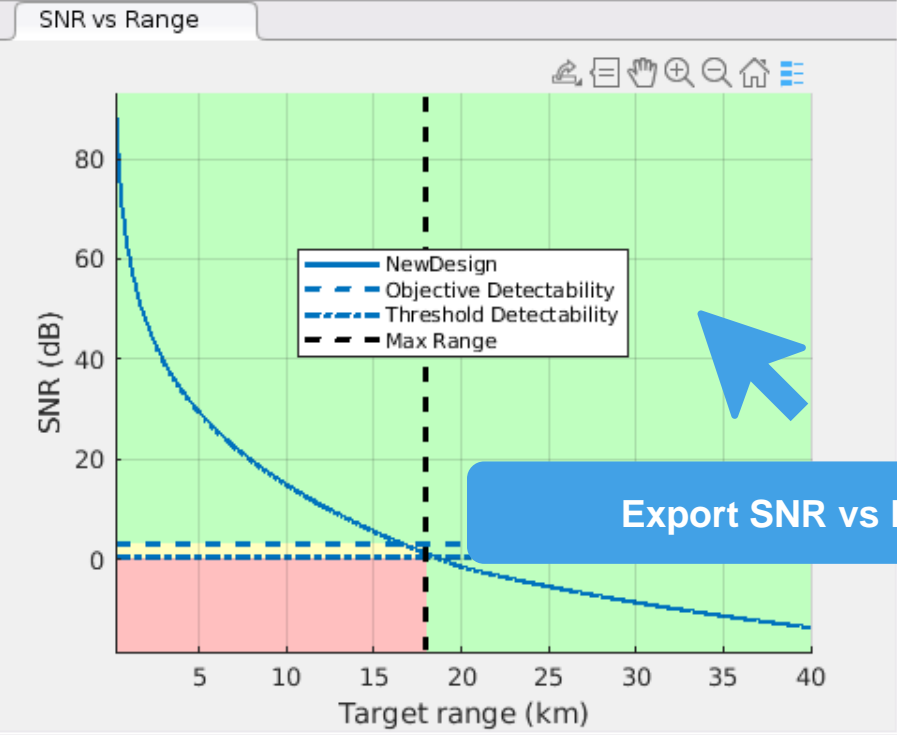

Generate script to recreate SNR vs Range plot for currently selected radar

Generate formatted report of numeric metrics

Export SNR vs Range

Metrics and Requirements

Metric	Units	Threshold	Objective	NewDesign
Probability of Detection		0.75	0.9	0.81 ⚠
Min Detectable Signal	dBm	-70	-90	-99 ✓
Min Range	m	5e+02	3e+02	3e+02 ✓
Unambiguous Range	km	8	18	21 ✓
Range Resolution	m	50	30	30 ✓
First Blind Speed	m/s	80	1e+02	1.1e+02 ✓
Range Rate Resolution	m/s	10	3	3.7 ⚠

EDITOR PUBLISH VIEW

New Open Save Find Files Compare Print FILE

Go To Find NAVIGATE

Insert Comment Indent EDIT

Breakpoints BREAKPOINTS

Run Run and Advance Run Section Advance Run and Time

Save and run to visualize SNR vs Range plot

```

1 % Generated by MATLAB(R) 9.11 (R2021b) and Radar Toolbox 1.0 (R2021b).
2 % Generated on: 20-Jan-2021 11:53:42
3
4 %% Set up radar, target, and environment structs for the currently
5 % Radar design parameters
6 radar = designRadar('NewDesign');
7
8 % Radar environment
9 env = radarEnvironment();
10
11 % Radar target
12 rangeLimits = [2.0000e+02 4.0000e+04]; % m
13 numTargetPositions = 1000;
14 target = radarTarget(radar,env,rangeLimits,numTargetPositions);
15
16 %% Define constraints and design requirements
17 % Constrain analysis in range
18 constraint.Range = 1.8000e+04; % m
19
20 % Set design requirements
21 PdThreshold = 7.5000e-01; % Decimal
22 PdObjective = 9.0000e-01; % Decimal
23
24 %% Compute available SNR for the currently selected radar
25 % Calculate propagation factor
26 Fprop = propagationFactor(radar,target);
27
28 % Calculate environmental losses
29 Latmos = atmosphericLosses(radar,env,target);
30
31 % Calculate range-dependent factors
32 Fcustom = rangeDependentLosses(radar,target);
33
34 % Calculate signal-to-noise ratio (SNR)

```

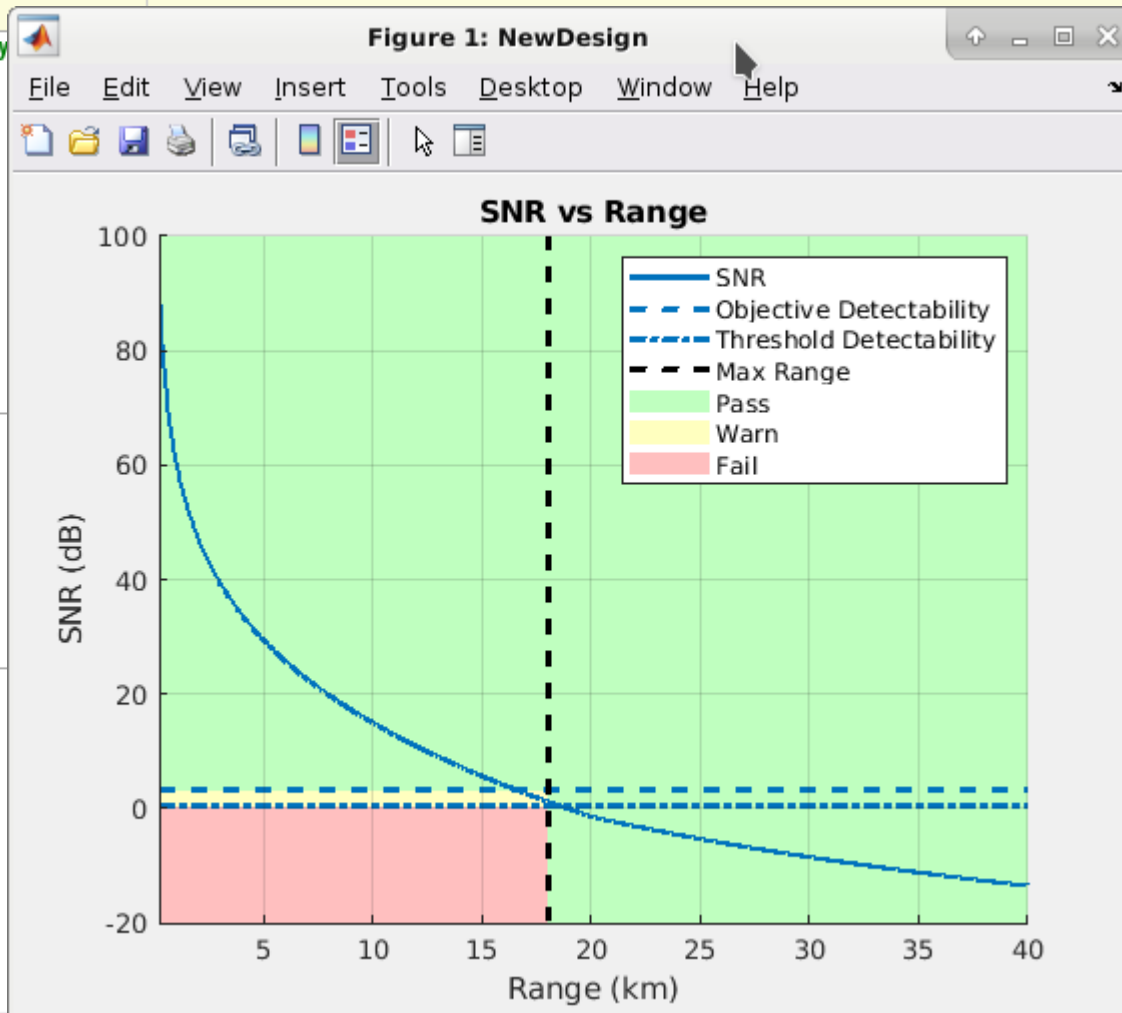

DESIGNER



FILE RADARS

Metric:

METRIC

ANALYSIS LAYOUT

Radar:
 Target:
 Environment:

Current Radar:

Name:

▼ Main

Frequency: GHz
 Pulse Bandwidth: MHz
 Peak Power: kW
 Pulse Width: μs
 PRF: kHz

▼ Hardware

Noise Temperature: K
 Reference Noise Temperature: K
 Quantization Noise

▼ Antenna and Scanning

Antenna Height: m
 Antenna Tilt Angle: deg
 Antenna Polarization:
 Transmit Antenna Gain Input:

Azimuth Beamwidth: deg
 Elevation Beamwidth: deg
 Gain: dBi

Use Different Antenna for Receive

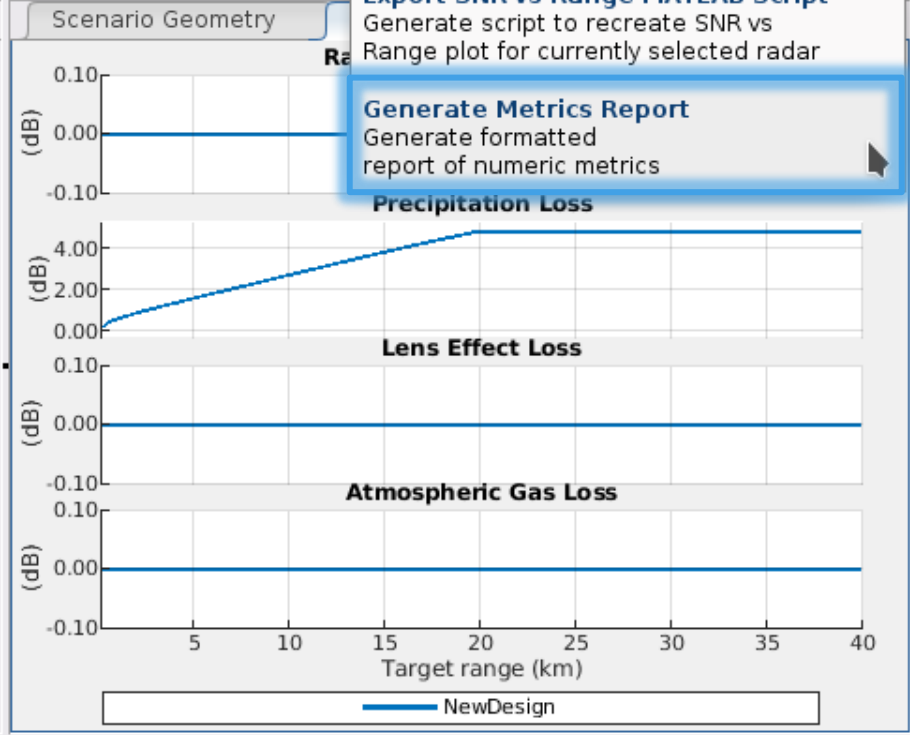
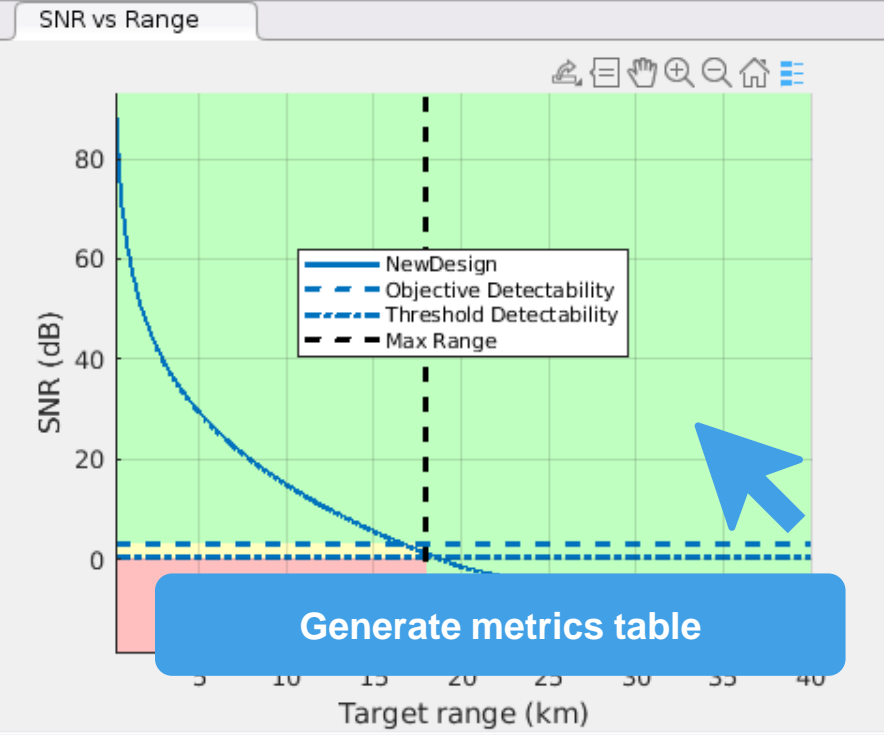

Metrics and Requirements

Metric	Units	Threshold	Objective	NewDesign
Probability of Detection		0.75	0.9	0.81 ⚠
Min Detectable Signal	dBm	-70	-90	-99 ✓
Min Range	m	5e+02	3e+02	3e+02 ✓
Unambiguous Range	km	8	18	21 ✓
Range Resolution	m	50	30	30 ✓
First Blind Speed	m/s	80	1e+02	1.1e+02 ✓
Range Rate Resolution	m/s	10	3	3.7 ⚠

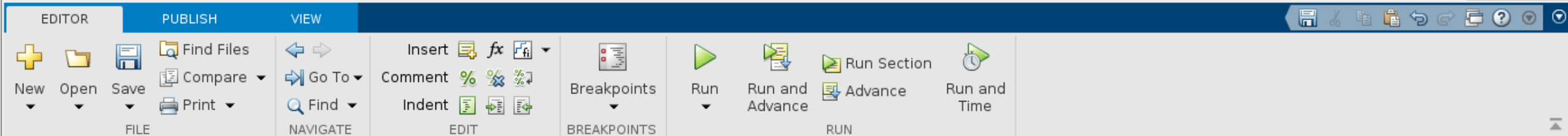

```
untitled5* x +
7 threshold = [0.75; -70; 500; 8; 50; 80; 10; 5; 0.4; 1; 3; 0.95; 1e-08; 1000; 3500];
8 objective = [0.9; -90; 300; 18; 30; 100; 3; 2; 0.2; 0.5; 1; 0.99; 1e-12; 2500; 4200];
9 radars = "NewDesign";
10 reqTable = table(units,threshold,objective);
11 reqTable.Properties.VariableNames = ["Units", "Threshold", "Objective"];
12 reqTable.Properties.RowNames = metrics;
13
14 % Create metric results table
15 results = [0.80886
16           -98.6125
17            299.7925
18             21.4137
19             29.9792
20            110.4499
21             3.6817
22             3.6932
23             0.30279
24             0.90836
25             0.45356
26             0.96347
27             1.8067e-13
28             5.4
29             0.42794];
30 resultsTable = splitvars(table(results));
31 resultsTable.Properties.VariableNames = "NewDesign";
32 resultsTable.Properties.RowNames = metrics;
33
34 % Create metrics and requirements table
35 metricsTable = cat(2,reqTable,resultsTable)
36
37 % Output metrics and requirements table to spreadsheet
38 % writetable(metricsTable,'metricsTable','FileType','spreadsheet','WriteRowNames',true)|
39
```

Uncomment this line to get a spreadsheet, which can be opened in Excel or other spreadsheet software

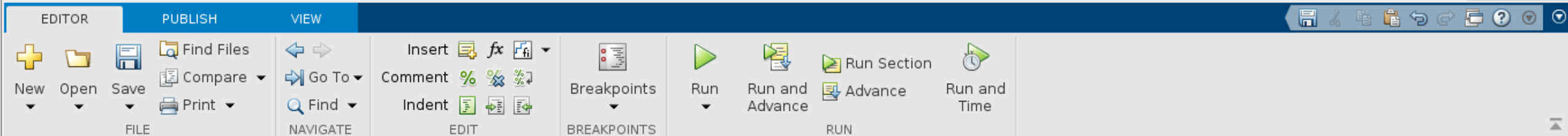

```
untitled5* x +
7 threshold = [0.75; -70; 500; 8; 50; 80; 10; 5; 0.4; 1; 3; 0.95; 1e-08; 1000; 3500];
8 objective = [0.9; -90; 300; 18; 30; 100; 3; 2; 0.2; 0.5; 1; 0.99; 1e-12; 2500; 4200];
9 radars = "NewDesign";
10 reqTable = table(units,threshold,objective);
11 reqTable.Properties.VariableNames = ["Units", "Threshold", "Objective"];
12 reqTable.Properties.RowNames = metrics;
13
14 % Create metric results table
15 results = [0.80886
16           -98.6125
17            299.7925
18             21.4137
19             29.9792
20            110.4499
21              3.6817
22              3.6932
23              0.30279
24              0.90836
25              0.45356
26              0.96347
27              1.8067e-13
28              5.4
29              0.42794];
30 resultsTable = splitvars(table(results));
31 resultsTable.Properties.VariableNames = "NewDesign";
32 resultsTable.Properties.RowNames = metrics;
33
34 % Create metrics and requirements table
35 metricsTable = cat(2,reqTable,resultsTable)
36
37 % Output metrics and requirements table to spreadsheet
38 writetable(metricsTable,'metricsTable','FileType','spreadsheet','WriteRowNames',true)
39
```

Uncomment this line to get a spreadsheet, which can be opened in Excel or other spreadsheet software

HOME PLOTS APPS

Design App Get More Apps Install App Package App Curve Fitting Signal Analyzer Wirel Wave RF Budget Analyzer Classifica... Deep Network ... Deep Network ...

Search Documentation Sign In

FILE APPS

home > sjames > MATLAB >

Current Folder

Name	Size	Date Modified
archive		01/11/2021 11:04:...
no_vc		01/14/2021 04:19:...
vc		04/10/2020 10:50:...
metricsTable.xls	12 KB	01/20/2021 11:55:...
NewDesign.m	6 KB	01/20/2021 11:53:...
NewDesignMetrics.m	2 KB	01/20/2021 11:54:...

Command Window

```
>> NewDesignMetrics
metricsTable =
15x4 table
```

	Units	Threshold	Objective	NewDesign
Probability of Detection	" "	0.75	0.9	0.80886
Min Detectable Signal	" dBm"	-70	-90	-98.612
Min Range	" m"	500	300	299.79
Unambiguous Range	" km"	8	18	21.414
Range Resolution	" m"	50	30	29.979
First Blind Speed	" m/s"	80	100	110.45
Range Rate Resolution	" m/s"	10	3	3.6817
Range Accuracy	" m"	5	2	3.6932
Azimuth Accuracy	" deg"	0.4	0.2	0.30279
Elevation Accuracy	" deg"	1	0.5	0.90836
Range Rate Accuracy	" m/s"	3	1	0.45356
Probability of True Track	" "	0.95	0.99	0.96347
Probability of False Track	" "	1e-08	1e-12	1.8067e-13
Effective Isotropic Radiated Power	" Mw"	1000	2500	5.4
Power-Aperture Product	" kW·m²"	3500	4200	0.42794

Workspace

Name	Value
metrics	15x1 string
metricsTable	15x4 table
objective	15x1 double
radars	"NewDesign"
reqTable	15x3 table
results	15x1 double
resultsTable	15x1 table
threshold	15x1 double
units	15x1 string

Command History

```
radarDesigner -debug
NewDesign
clc
clear all
close all
clc
NewDesignMetrics
openExample('radar...
2x radarDesigner -debug
NewDesign
NewDesignMetrics
clc
clear all
close all
clc
NewDesignMetrics
```

Details

Select a file to view details

Metrics report output

3 Things We'll Cover Today

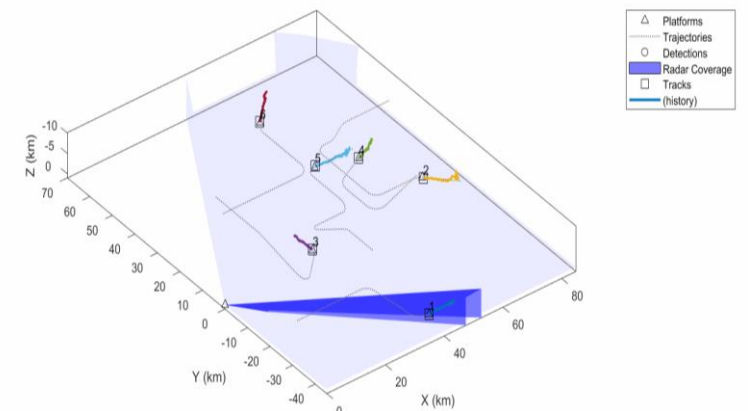
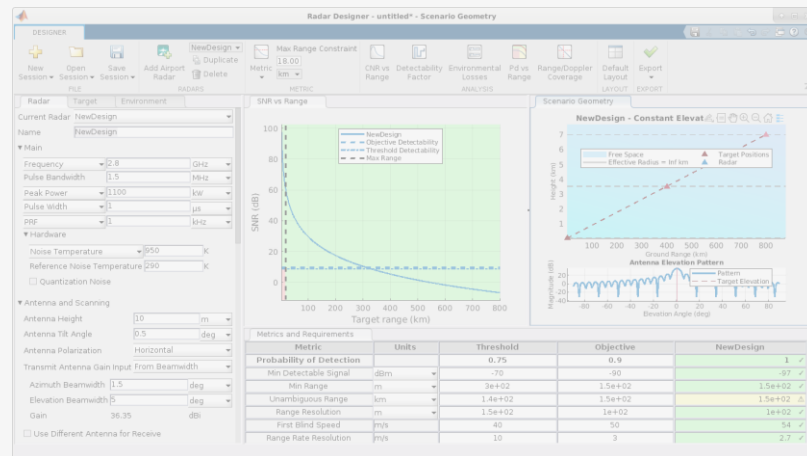
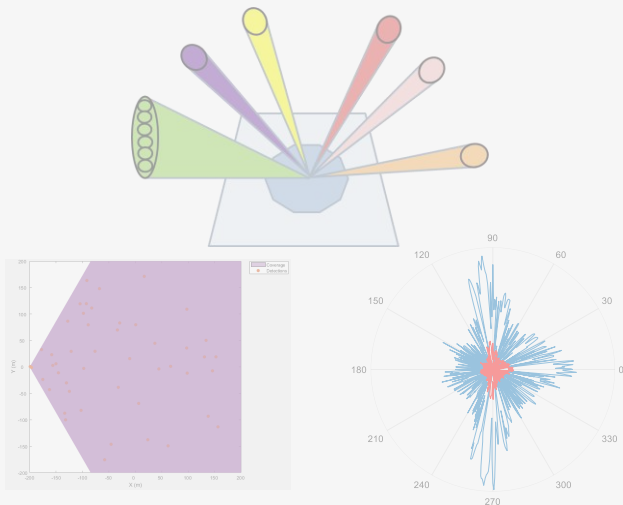

Challenges

Multifunction operations in harsh environmental conditions for smaller targets

Radar System Engineering

Making engineering trade-offs early in the design cycle

Modeling and Simulation

Selecting the right level of model abstraction

Authoring surface, air and space scenarios for radar applications



Object Dimensions

bounding box

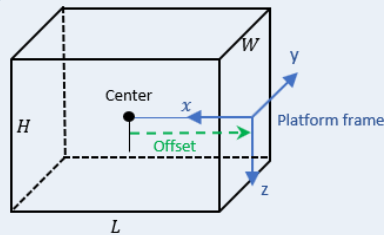

RCS signature

Az, el pattern

frequencies dependency

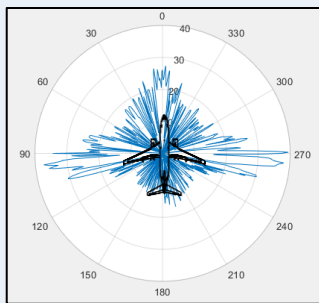

Use kinematic properties

acceleration, angular velocity

Use waypoints

position, orientation, time of arrival,
ground speed, climb rate

fixed NED or ENU frame (x,y,z) or,
geo-referenced (lat, lon, alt)

Radars on platforms

Mounting position and orientation of
radar sensor on platform

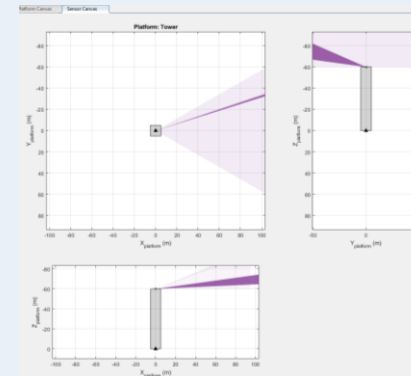

INS sensor

platform self-awareness

sensor to platform frame conversion

Generate radar data

I/Q signals, detections, tracks

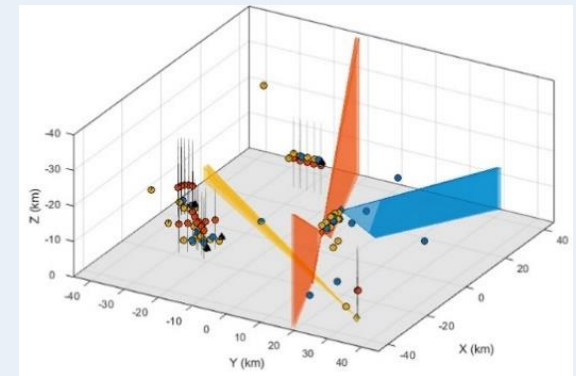

Monte Carlo

perturb ground truth and sensor
to increase testing robustness

You can also evaluate detectability for the scenario

Line-of-sight (LOS) and SNR over terrain

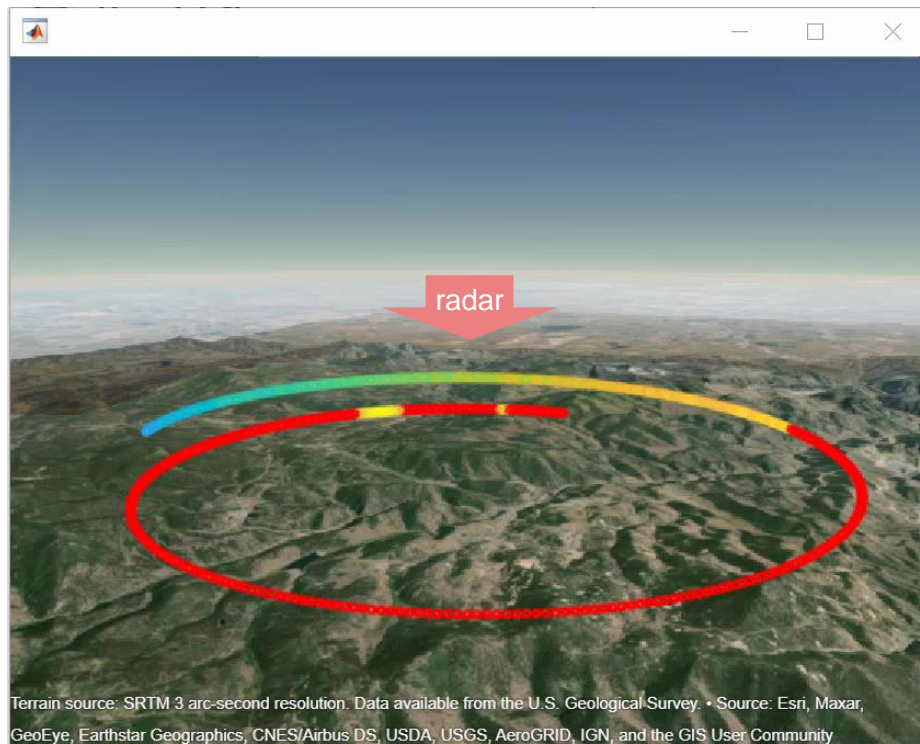

Colors other than red: SNR
Red: No LOS

Iterate on design to increase detectability

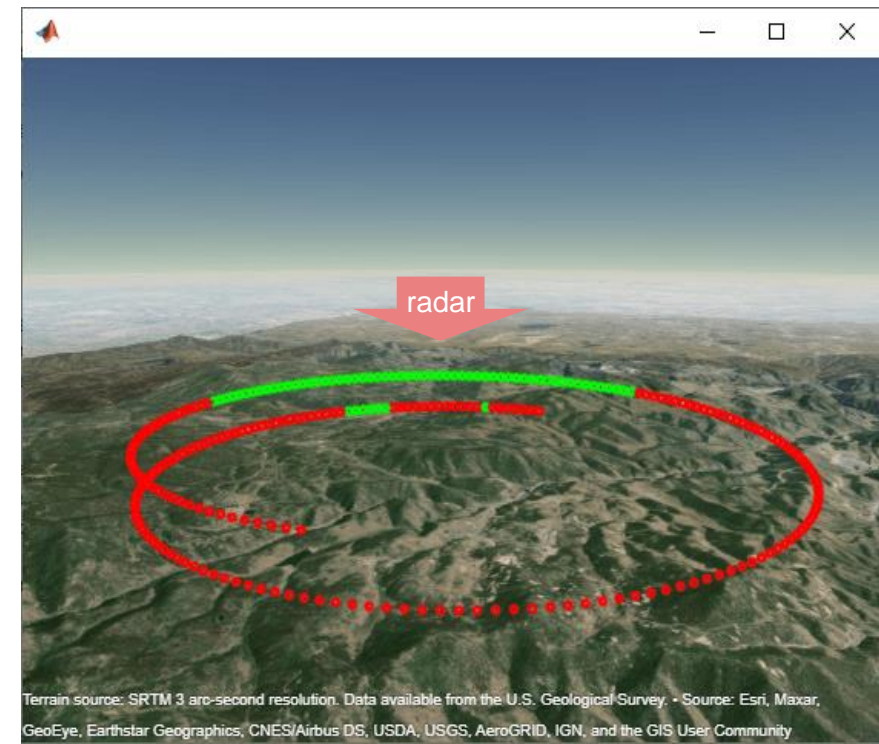

Green: Target detectable
Red: No LOS/target non detectable

Poll question

- What can we do to increase the target's detectability (select all that apply)?
 - a) Increase the radar transmit power
 - b) Integrate the radar returns over multiple pulses
 - c) Increase the height of antenna
 - d) Turn off the target's cloaking device

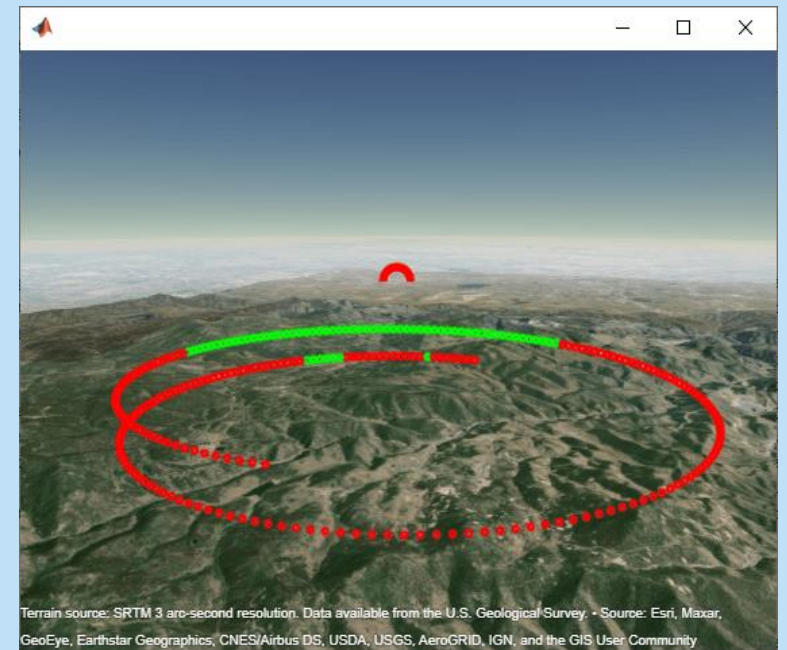

Radar Modeling and Simulation

Model
Platforms and Targets

Model
Trajectories

Model
Sensors

Simulate
scenarios

```

for m = 1:num_pulse_int

    % Update sensor and target positions
    [sensorpos,sensorvel] = sensormotion(1/prf);
    [tgtpos,tgtvel] = tgtmotion(1/prf);

    % Calculate the target angles as seen by the sensor
    [tgtrng,tgtang] = rangeangle(tgtpos, sensorpos);

    % Simulate propagation of pulse in direction of targets
    pulse = waveform();
    [txsig,txstatus] = transmitter(pulse);
    txsig = radiator(txsig,tgtang);
    txsig = channel(txsig,sensorpos,tgtpos,sensorvel,tgtvel);

    % Reflect pulse off of targets
    tgtsig = target(txsig);

    % Receive target returns at sensor
    rxsig = collector(tgtsig,tgtang);
    rxpulses(:,m) = receiver(rxsig,~(txstatus>0));

end
  
```

Modify Simulation Parameters

Wideband Radar with One Target in a Separable Multipath Environment

Info

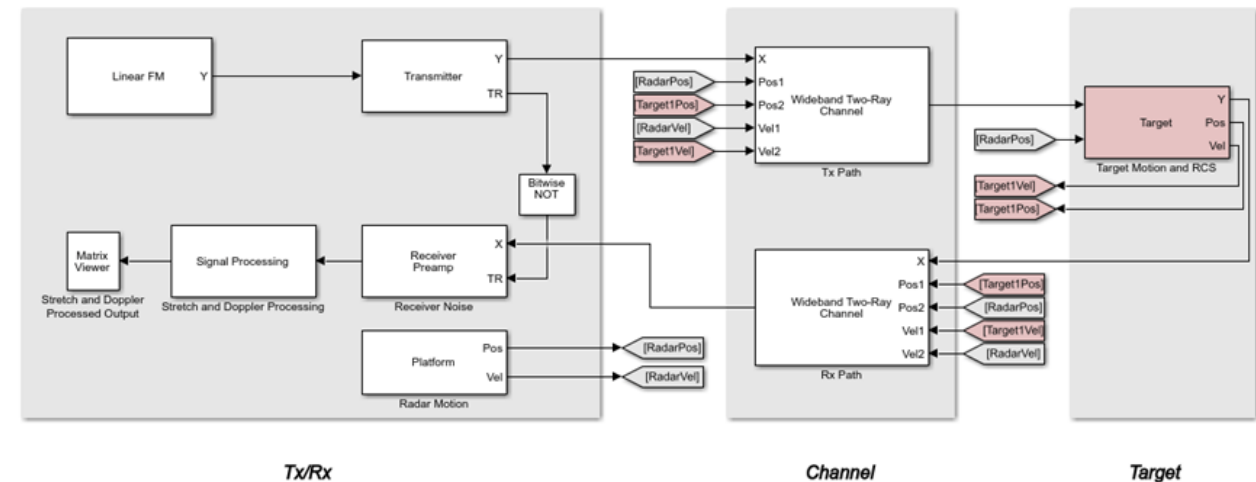

Radar Modeling and Simulation

Model
Platforms and Targets

Model
Trajectories

Model
Sensors

Simulate
scenarios

```
sensor =
radarDataGenerator with properties:
    SensorIndex: 1
    UpdateRate: 53.5714
    DetectionMode: 'Monostatic'
    ScanMode: 'Mechanical'
    InterferenceInputPort: 0
    EmissionsInputPort: 0
    MountingLocation: [0 0 -15]
    MountingAngles: [0 0 0]
    FieldOfView: [1.4000 5]
    RangeLimits: [0 100000]
    DetectionProbability: 0.9000
    FalseAlarmRate: 1.0000e-06
    ReferenceRange: 100000
    TargetReportFormat: 'Clustered detections'
Show all properties
```

```
sensor_iq =
radarTransceiver with properties:
    Waveform: [1x1 phased.LinearFMWaveform]
    Transmitter: [1x1 phased.Transmitter]
    TransmitAntenna: [1x1 phased.Radiator]
    ReceiveAntenna: [1x1 phased.Collector]
    Receiver: [1x1 phased.ReceiverPreamplifier]
    MechanicalScanMode: 'Circular'
    InitialMechanicalScanAngle: -0.1000
    MechanicalScanRate: 75
    ElectronicScanMode: 'None'
    MountingLocation: [0 0 -15]
    MountingAngles: [0 0 0]
    NumRepetitionsSource: 'Property'
    NumRepetitions: 1
```

Radar data synthesis spans a range of fidelity levels

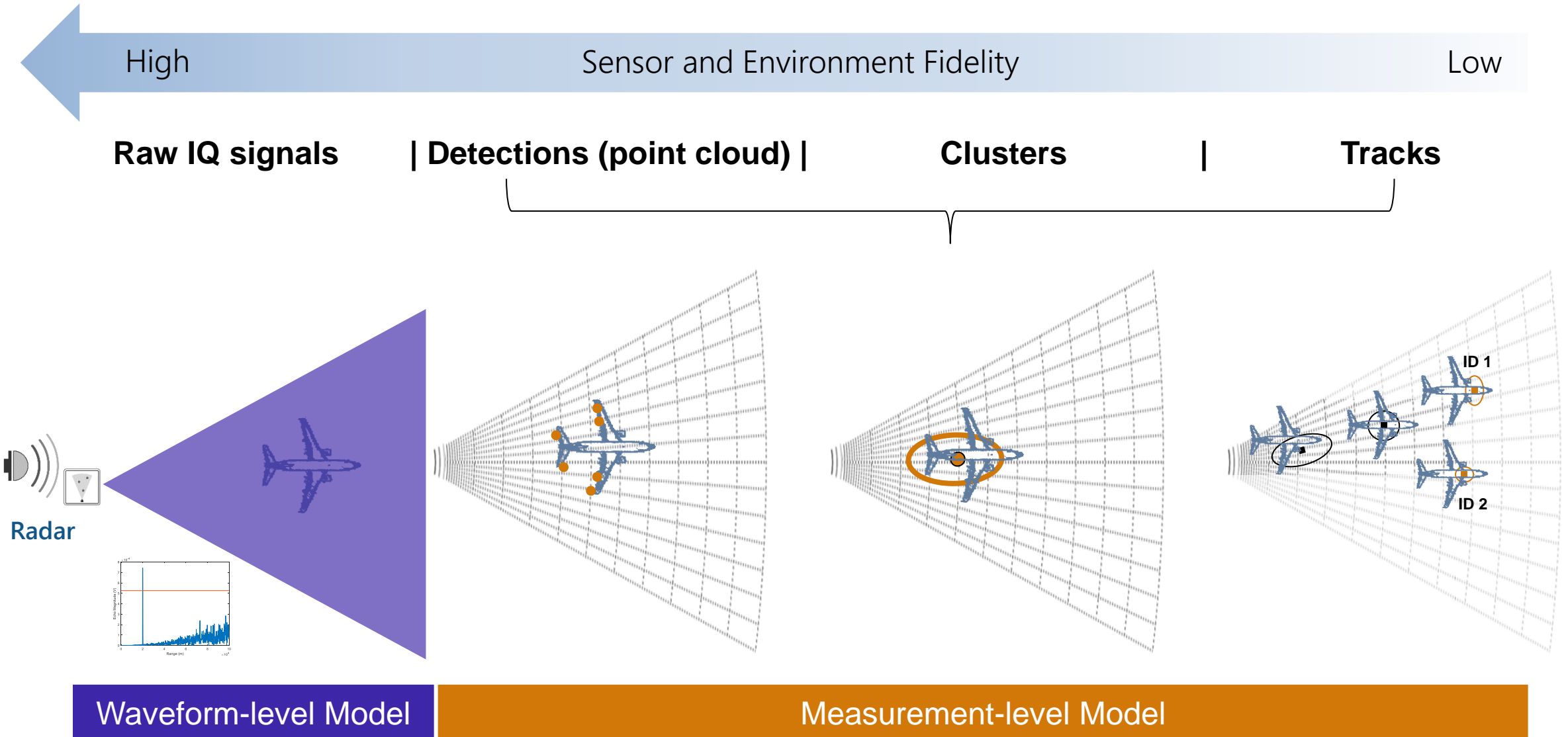

Dynamically switch between waveform-level & measurement-level models

```

sensor =
    radarDataGenerator with properties:
        SensorIndex: 1
        UpdateRate: 53.5714
        DetectionMode: 'Monostatic'
        ScanMode: 'Mechanical'
        InterferenceInputPort: 0
        EmissionsInputPort: 0
        MountingLocation: [0 0 -15]
        MountingAngles: [0 0 0]
        FieldOfView: [1.4000 5]
        RangeLimits: [0 100000]
        DetectionProbability: 0.9000
        FalseAlarmRate: 1.0000e-06
        ReferenceRange: 100000
        TargetReportFormat: 'Clustered detections'
    
```

```
sensor_iq = radarTransceiver(sensor);
```

```

sensor_iq =
    radarTransceiver with properties:
        Waveform: [1x1 phased.LinearFMWaveform]
        Transmitter: [1x1 phased.Transmitter]
        TransmitAntenna: [1x1 phased.Radiator]
        ReceiveAntenna: [1x1 phased.Collector]
        Receiver: [1x1 phased.ReceiverPreamp]
        MechanicalScanMode: 'Circular'
        InitialMechanicalScanAngle: -0.1000
        MechanicalScanRate: 75
        ElectronicScanMode: 'None'
        MountingLocation: [0 0 -15]
        MountingAngles: [0 0 0]
        NumRepetitionsSource: 'Property'
        NumRepetitions: 1
    
```

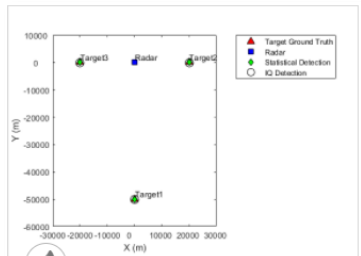

Transitioning From Statistical to Physics Based Radar Models

This treats a radar as a perception system that uses an antenna or antenna array to capture RF energy.

[Open Live Script](#)

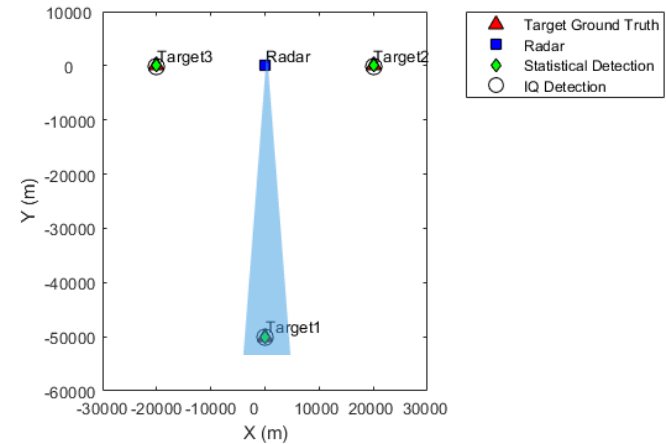
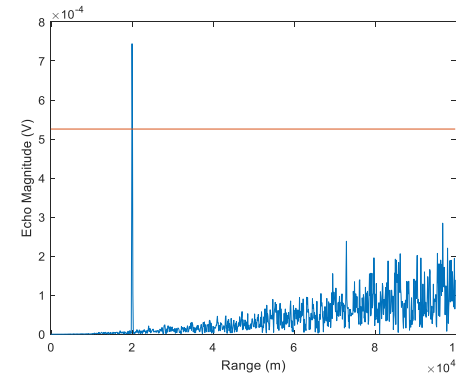
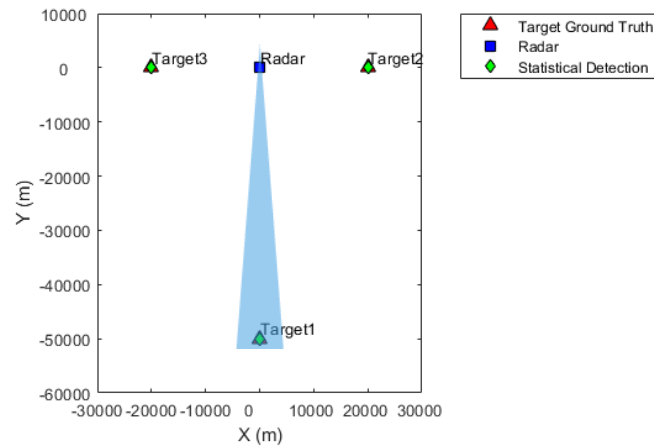

Measurement-level Model
(Statistical)

Waveform-level Model
(Physics-based)

You can then apply a range of signal and data processing algorithms

Beamforming

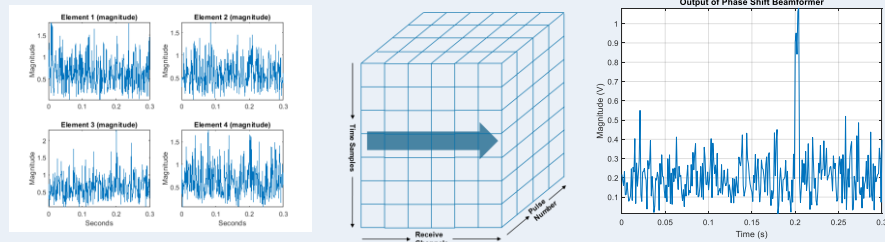

Matched filtering

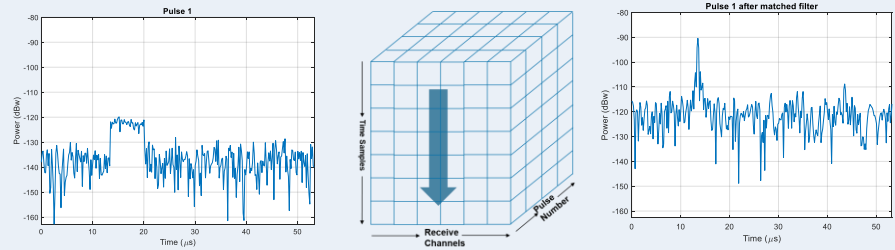

Doppler processing

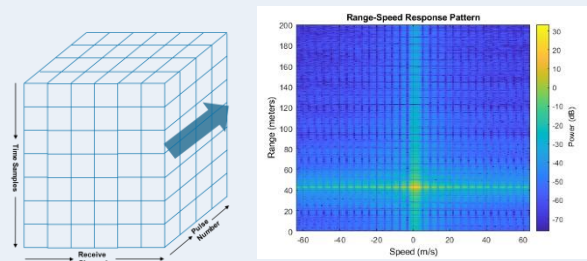

before

after

Detection (CFAR)

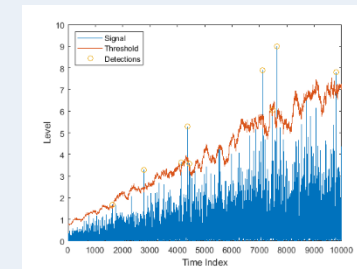
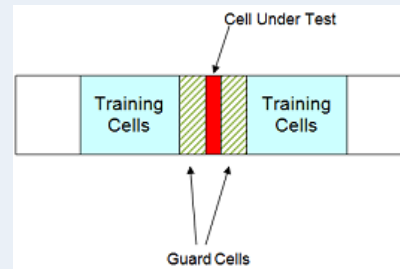

Clustering (DBSCAN)

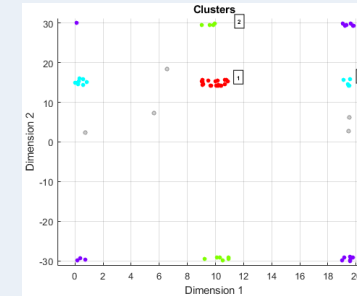
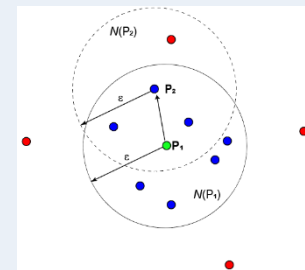

Tracking

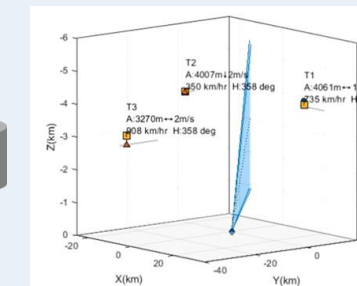
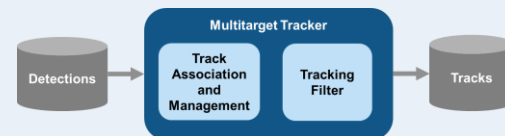

These types of models can scale to larger radar systems

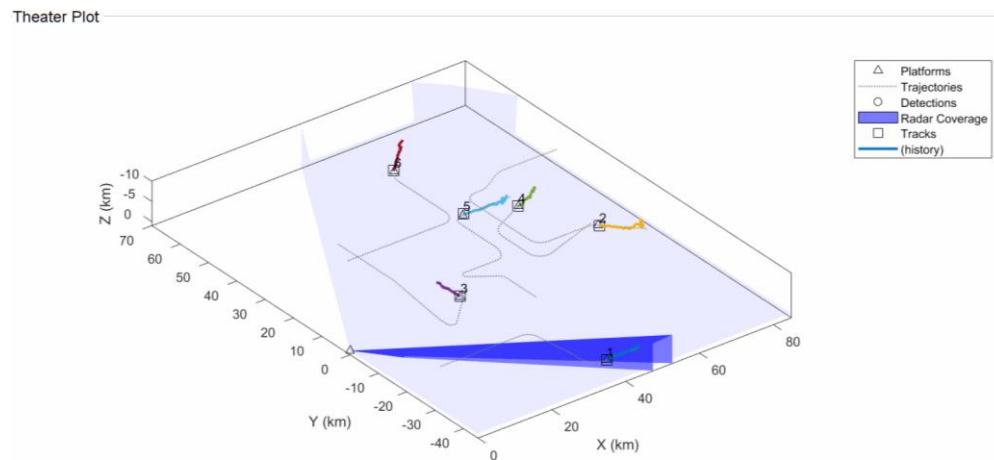

Multifunction Radar

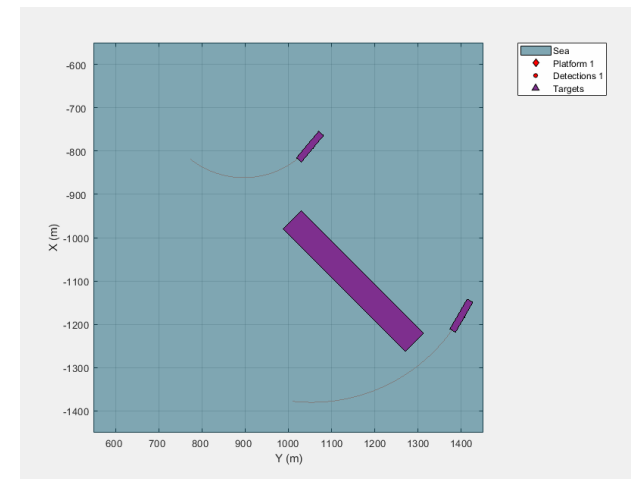

Maritime surveillance

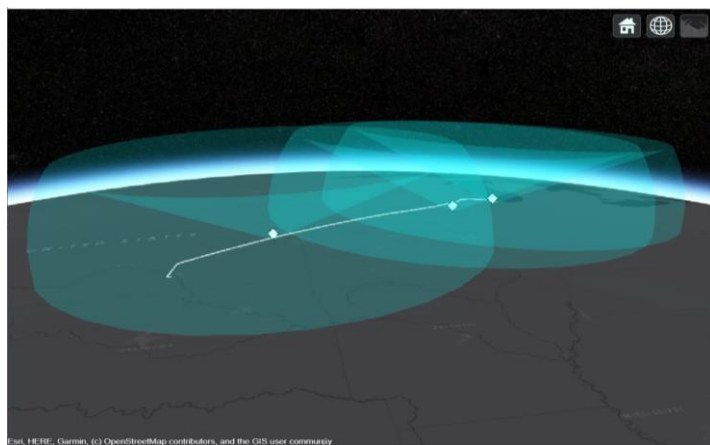

System of radar systems

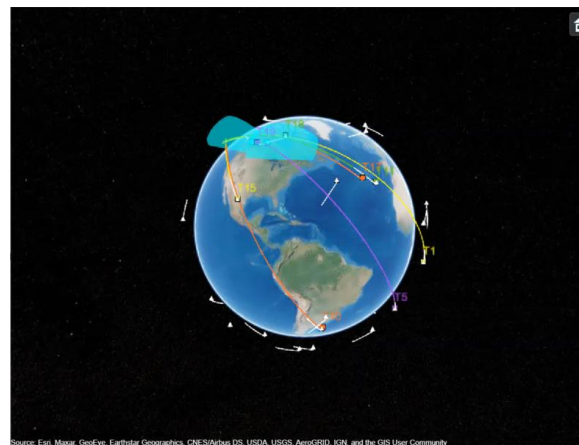

Space tracking

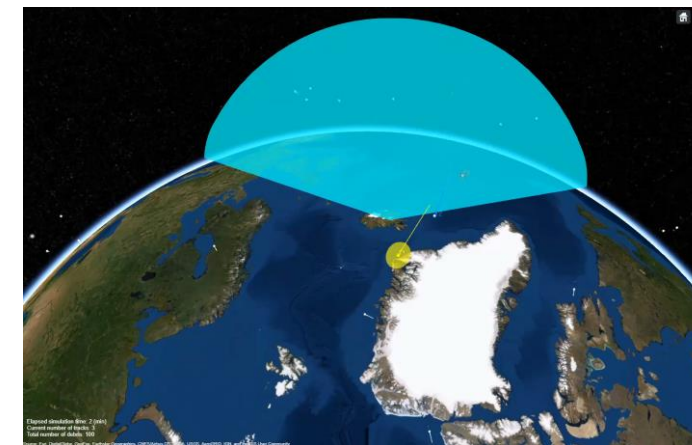

Download handout with more information related to this session

Radar Architecture Modeling: System partitioning & requirements allocation

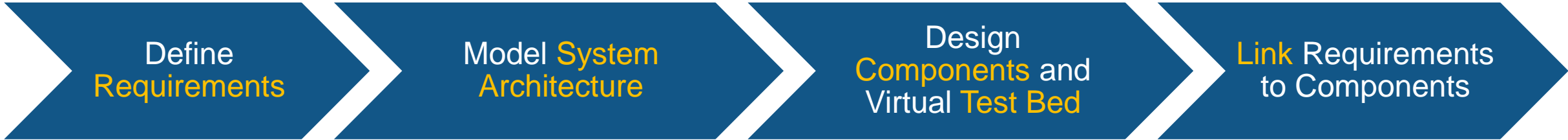

Detection

Detect a target with 1m^2 RCS at 6 km
Pd must be at least 0.9
Pfa must be no more than $1\text{e-}6$

Resolution

Resolve targets that are 70 m apart in range

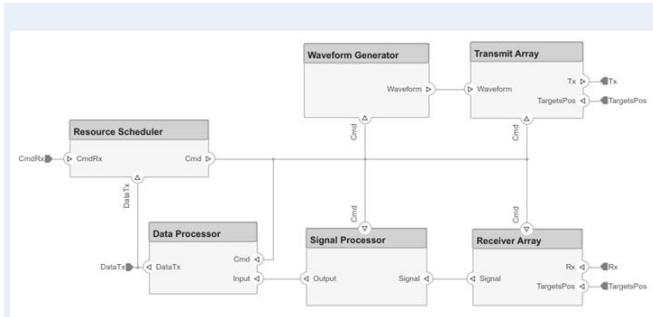

using System Composer™

Metric	Units	Threshold	Objective	Target
Max Range	km	6.00	6.00	6.00
Min Detectable Signal	dBm	-93.00	-93.00	-93.00
Min Range	km	0.00	0.00	0.00
Unambiguous Range	km	6.00	6.00	6.00
Range Resolution	m	70.00	70.00	70.00

Apps

- Pulse Waveform Analyzer
- Sensor Array Analyzer
- Radar Designer

ID	Summary	Verified	Implemented
R1	Maximum range	Yes	Yes
R2	Range resolution	Yes	Yes

using Simulink Requirements™

Test automation & requirements traceability: Manage changing requirements



Blocks Libraries

Waveforms, Tx/Rx arrays, signal processing algorithms, targets, channels, clutter, etc.

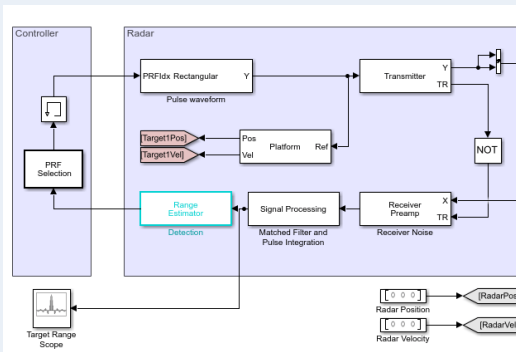

using Simulink

App Test Manager

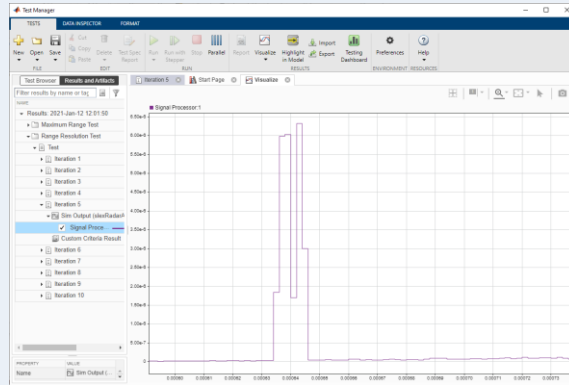

using Simulink Test™

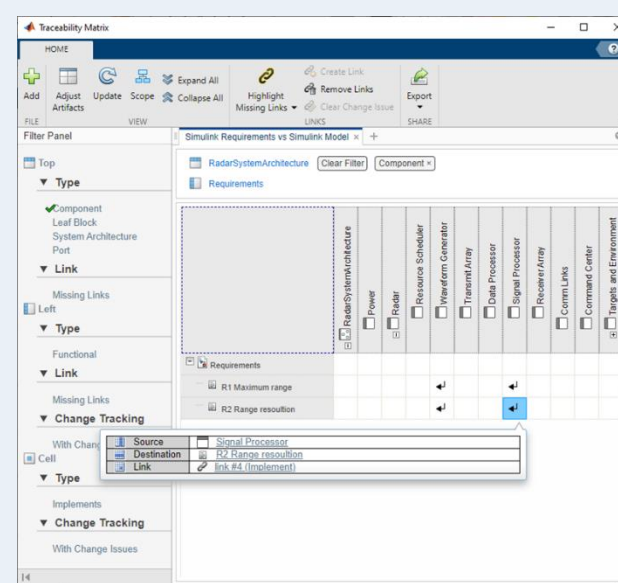

using Simulink Test™
using Simulink Requirements™

Automated process enables quick iterations

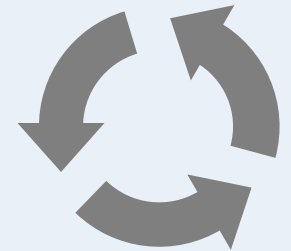

PARAMETER OVERRIDES*

PARAMETER SET / WORKSPACE VARIABLE	OVERRIDE VALUE
<ul style="list-style-type: none"> Parameter Set 1 <ul style="list-style-type: none"> tgtpos tgtrcs tgtvel 	<ul style="list-style-type: none"> [8000;0;0] 1 [0;0;0]

using Simulink Requirements™

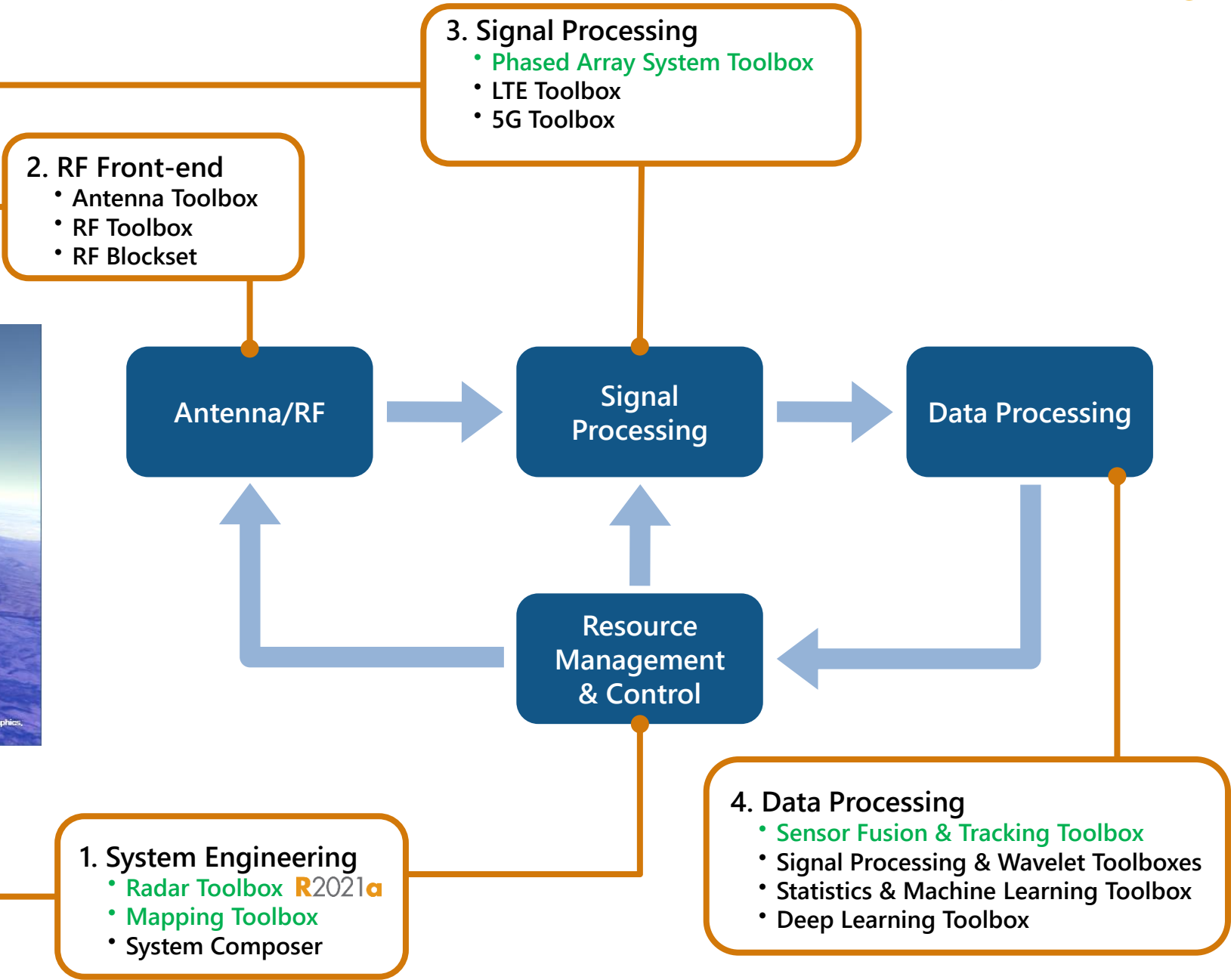

Green indicates tools used in this session

MATLAB, Simulink, & Radar Toolbox can help you with radar system design

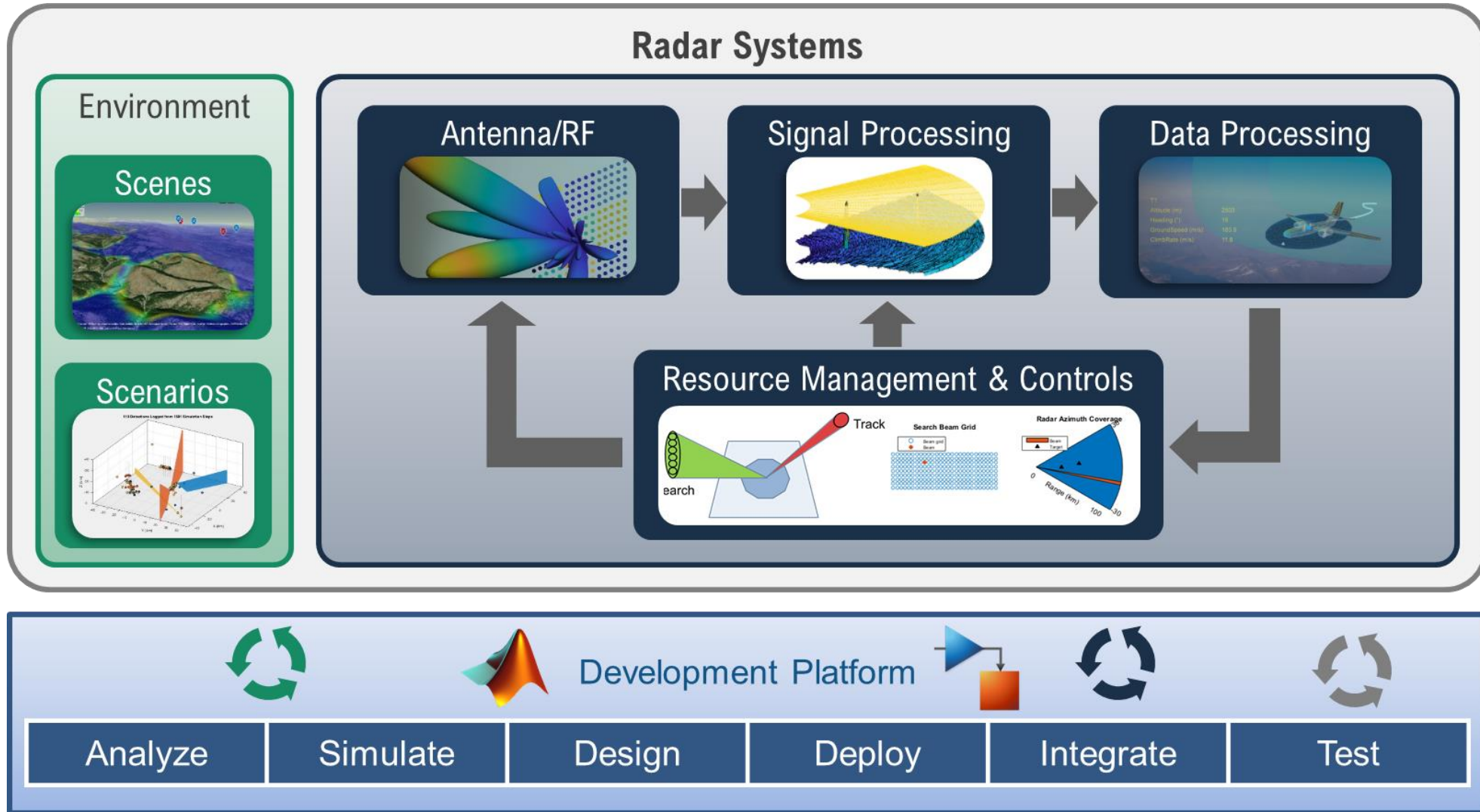

Please visit our website for more information



MATLAB and Simulink for Radar Systems

Design, simulate, test, and deploy multifunction radar systems

<https://www.mathworks.com/solutions/aerospace-defense/radar-systems.html>

MATLAB EXPO

2021

Thank you

